

Incremental Encoders

Large hollow shaft, optical

5821 (Hollow shaft)

Push-Pull / RS422



Optimised proportions, optimised costs:

With an overall diameter of just 58 millimetres the series 5821 boasts a hollow shaft of up to 28 millimetres diameter

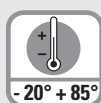

Temperature



Shock / vibration resistant



Magnetic field proof



Short-circuit proof



Reverse polarity protection

Adaptable

- Through hollow shaft from 16 mm up to 28 mm
- With cable connection or M12 connector
- High resolution up to 5000 PPR

Order code Hollow shaft

8.5821 . 1 X X X . X X X X
Type a b c d e

a Flange
 1 = with spring element

b Hollow shaft
 3 = ø 28 mm
 5 = ø 25 mm
 6 = ø 24 mm
 C = ø 20 mm
 K = ø 16 mm
 (other on request)

c Output circuit / Power supply
 1 = RS422 (with inverted signal) / 5 V DC
 3 = Push-pull (with inverted signal) / 8 ... 30 V DC
 4 = RS422 (with inverted signal) / 8 ... 30 V DC

d Type of connection
 1 = radial cable (1 m PVC cable)
 E = M12 connector, 8-pin, radial

e Pulse rate
 50, 60, 100, 125, 250, 400, 500, 512, 960, 1000, 1024, 2000, 2048, 5000
 (e.g. 100 pulses => 0100)

Other pulse rates on request

Connection Technology

Connector, self-assembly (straight)

M12

05.CMB-8181-0

Cordset, pre-assembled with 2 m PVC cable

M12

05.WAKS8-2/P00

Further accessories can be found in the Accessories section or in the Accessories area of our website at: www.kuebler.com/accessories.
 Additional connectors can be found in the Connection Technology section or in the Connection Technology area of our website at: www.kuebler.com/connection_technology.

Terminal assignment

Signal:	0 V GND	+U _B	A	\bar{A}	B	\bar{B}	0	$\bar{0}$	shield
M12 connector, eurofast, 8-pin, Pin	1	2	3	4	5	6	7	8	PH ¹⁾
Cable colour	WH	BN	GN	YE	GY	PK	BU	RD	shield

Top view of mating side, male contact base

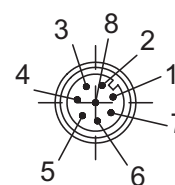

8-pin M12 connector

1) PH = Shield is attached to connector housing

Incremental Encoders

Large hollow shaft, optical **5821 (Hollow shaft)** **Push-Pull / RS422**

Mechanical characteristics	
Speed	max. 2500 min ⁻¹
Rotor moment of inertia	approx. 3.5 x 10 ⁻⁶ kgm ²
Starting torque	< 0.1 Nm
Weight	approx. 0.4 kg
Protection acc. to EN 60 529	IP64
Working temperature range	
at max. speed 2000 min ⁻¹	-20°C ... +70°C
at max. speed 2500 min ⁻¹	-20°C ... +60°C
Materials	steel
Shock resistance acc. to EN 60068-2-27	1000 m/s ² , 6 ms
Vibration resistance acc. to EN 60068-2-6	100 m/s ² , 35...2000 Hz

Electrical characteristics		
Output circuit	RS 422	Push-Pull (7272)
Supply voltage	5 V ±5% / 8 ... 30 V DC	8 ... 30 V DC
Power consumption with inverted signal (no load)	typ. 40 mA/max. 90 mA	typ. 40 mA/max. 100 mA
Permissible load/channel	max. ±20 mA	max. ±40 mA
Pulse frequency	max. 300 kHz	max. 200 kHz
Signal level	high low	min. 2.5 V max. 0.5 V
Rise time t_r	max. 200 ns	max. 1 µs
Fall time t_f	max. 200 ns	max. 1 µs
Short circuit proof outputs ¹⁾	yes	yes
Reverse connection of the supply voltage	yes	yes
CE compliant acc. to	EN 61000-6-2, EN 55011 Class B	
RoHS compliant acc. to	EU guideline 2002/95/EG	

Incremental Encoders

Dimensions

Flange with torque stop, ø 58 mm
Cable version, connection type 1

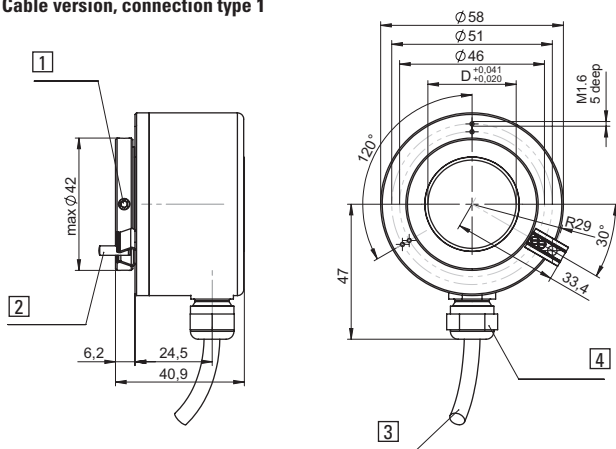

- 1 4 x socket set screw M4x6 DIN 913
- 2 Cylindrical pin 3m6x12 DIN 6325 included
- 3 Cable length 2 metres
- 4 Cable gland PG7

M12 connector version, connection type E

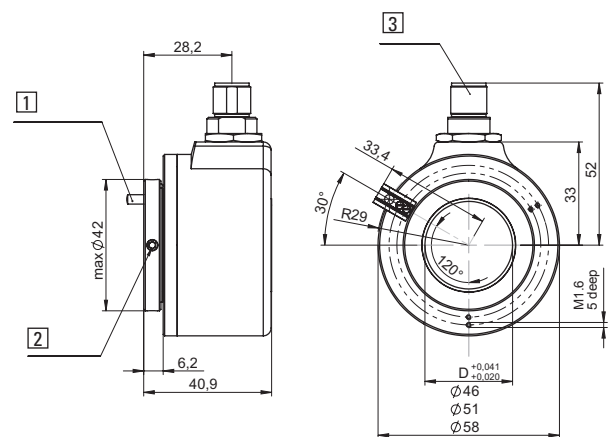

- 1 4 x socket set screw M4x6 DIN 913
- 2 Cylindrical pin 3m6x12 DIN 6325 included
- 3 Connector M12

1) If supply voltage correctly applied.
2) PH = Shield is attached to connector housing