

# Absolute Encoders - Singleturn

**Standard, optical**      **5850 / 5870 (Shaft / Hollow shaft)**      **Parallel, Analogue**



The singleturn encoders 5850 and 5870 with parallel or analogue interface and optical sensor technology feature a refresh rate of the position data of 1.6 kHz.

With the parallel output a resolution of max. 14 bit can be achieved – with the analogue output the 4 ... 20 mA signals can achieve a resolution of 13 bits.



High rotational speed	Temperature -20° + 85°	High IP value	High shaft load capacity	Shock / vibration resistant	Magnetic field proof	Optical sensor

### Adaptable

- Power supply 5 V DC or 10 ... 30 V DC
- Cable or connector
- Gray code, Binary code or BCD code

### Robust

- High shock resistance
- Temperature range from -20°C up to +85°C
- Protection rating up to max. IP66

Absolute Encoders Singleturn

<b>Order code</b>	<b>8.5850</b>	.	X	X	X	X	.	X	X	X
<b>Shaft version</b>	Type		a	b	c	d		e	f	

<b>a</b> Flange 1 = clamping flange 2 = synchro flange	<b>c</b> Output circuit/ Power supply 3 = Parallel / 5 V 4 = Parallel / 10 ... 30 V 7 = 4 ... 20 mA / 5 V 8 = 4 ... 20 mA / 10 ... 30 V	<b>d</b> Type of connection 1 = axial cable (1 m PVC) 2 = radial cable (1 m PVC) 3 = M23 connector, axial, without mating connector 5 = M23 connector, radial, without mating connector	<b>f</b> Options 2 = SET <sup>1)</sup> and V/R 3 = SET and Latch <sup>1)</sup> 4 = V/R <sup>1)</sup> and Latch
<b>b</b> Shaft (ø x L), with flat 1 = 6 x 10 mm 2 = 10 x 20 mm		<b>e</b> Code type and Division G13 = 13 bit (for interface 7 and 8, 4 ... 20 mA) see Table 1 (for interface 3 and 4, Parallel)	

<b>Order code</b>	<b>8.5870</b>	.	X	X	X	X	.	X	X	X
<b>Hollow shaft</b>	Type		a	b	c	d		e	f	

<b>a</b> Flange with torque stop set 1 = and through hollow shaft 2 = with blind hollow shaft <i>Flange with stator coupling</i> 3 = and through hollow shaft 4 = with blind hollow shaft	<b>b</b> Hollow shaft 6 = ø 10 mm 8 = ø 12 mm	<b>d</b> Type of connection 1 = radial cable (1 m PVC) 2 = M23 connector, radial, without mating connector	<b>f</b> Options 2 = SET <sup>1)</sup> and V/R 3 = SET and Latch <sup>1)</sup> 4 = V/R and Latch <sup>1)</sup>
	<b>c</b> Output circuit/ Power supply 3 = Parallel / 5 V DC 4 = Parallel / 10 ... 30 V DC	<b>e</b> Code type and Division see Table 1 (for interface 3 and 4, Parallel)	

Table 1: Code type and Divisions for encoders with parallel output										Interface and Supply Voltage, version 3 or 4 (Parallel)										
Division	250	360	500	720	900	1000	1024 10 bit	1250	1440	1800	2000	2500	2880	3600	4000	4096 12 bit	5000	7200	8192 13 bit	16384 14 bit
<b>Order code Gray/Gray-Excess</b>	E02	E03	E05	E07	E09	E01	G10	E12	E14	E18	E20	E25	E28	E36	E40	G12	E50	E72	G13	G14
<b>Order code Binary</b>	B02	B03	B05	B07	B09	B01	B10	BA2	BA1	B18	B20	B25	B28	B36	B40	B12	B50	B72	B13	B14
<b>Order code BCD</b>	D02	D03	D05	D07	D09	D01	D10	DA2	DA1	D18	D20									

1) For Parallel version, 14 bit and 17 pin connector

# Absolute Encoders - Singleturn

Standard, optical	5850 / 5870 (Shaft / Hollow shaft)	Parallel, Analogue
<b>Mounting accessory for shaft encoders</b>		
<b>Coupling</b>	Bellows coupling ø 19 mm for shaft 6 mm	8.0000.1101.0606
	Bellows coupling ø 19 mm for shaft 10 mm	8.0000.1101.1010
<b>Mounting accessory for hollow shaft encoders</b>		
<b>Cylindrical pin, long</b> for torque stops		With fixing thread 8.0010.4700.0000
<b>Connection Technology</b>		
<b>Connector, self-assembly</b>	M23, 12 pin for analogue interface	8.0000.5012.0000
	M23, 17 pin for parallel interface	8.0000.5042.0000
<b>Cordset, pre-assembled with 2 m PVC cable</b>	M23, for analogue interface	8.0000.6901.0002.0031
	M23, for parallel interface	8.0000.6741.0002

Further accessories can be found in the Accessories section or in the Accessories area of our website at: [www.kuebler.com/accessories](http://www.kuebler.com/accessories).  
Additional connectors can be found in the Connection Technology section or in the Connection Technology area of our website at: [www.kuebler.com/connection\\_technology](http://www.kuebler.com/connection_technology).

Mechanical characteristics		
<b>Max. speed</b>	shaft version	max. 12000 min <sup>-1</sup>
	hollow shaft version	max. 6000 min <sup>-1</sup> 1)
<b>Rotor moment of inertia</b>	shaft version	ca. 1.8 x 10 <sup>-6</sup> kgm <sup>2</sup>
	hollow shaft version	ca. 6 x 10 <sup>-6</sup> kgm <sup>2</sup>
<b>Starting torque</b>	shaft version	< 0.01 Nm
	hollow shaft version	< 0.05 Nm
<b>Load capacity of shaft</b>	radial	80 N
	axial	40 N
<b>Weight</b>		ca. 0.4 kg
<b>Protection acc. to EN 60 529</b>	shaft version	IP65
	hollow shaft version	IP66
<b>Working temperature range</b>		-20°C ... +85°C 2) 3)
<b>Material</b>	shaft / hollow shaft	stainless steel
<b>Shock resistance acc. EN 60068-2-27</b>		2500 m/s <sup>2</sup> , 6 ms
<b>Vibration resistance acc. EN 60068-2-6</b>		100 m/s <sup>2</sup> , 10...2000 Hz

Electrical characteristics Parallel interface		
<b>Power supply (U<sub>B</sub>)</b>	5 V DC (± 5 %)	10 ... 30 V DC
<b>Output driver</b>	Push-Pull	Push-Pull
<b>Power consumption (no load)</b>	typ.	109 mA
	max.	169 mA
<b>Permissible load / channel</b>	max. +/- 10 mA	max. +/- 10 mA
<b>Refresh rate of the position data</b>	1.600/s	1.600/s
<b>Signal level</b>	high	min. 3.4 V
	low (I <sub>Load</sub> = 10 mA)	max. 1.5 V
	low (I <sub>Load</sub> = 1 mA)	max. 0.3 V
<b>Rising edge time tr (without cable)</b>		max. 0.2 µs
		max. 1 µs
<b>Falling edge time tf (without cable)</b>		max. 0.2 µs
		max. 1 µs
<b>Short circuit proof outputs</b>	no	no
<b>Reverse connection of the supply voltage</b>	no	yes
<b>UL-certified</b>		File 224618
<b>CE compliant acc. to</b>		EN 61000-6-2, EN 61000-6-4 and EN 61000-6-3
<b>RoHS compliant acc. to</b>		EU guideline 2002/95/EG

Electrical characteristics current interface 4 ... 20 mA		
(only shaft version)		
<b>Sensor</b>		
<b>Interface type</b>	4 ... 20 mA	4 ... 20 mA
<b>Power supply (U<sub>B</sub>)</b>	10 ... 30 V DC	5 V DC
<b>Power consumption (no load)</b>	typ.	70 mA
	max.	84 mA
<b>Current loop</b>		
<b>Power supply (U<sub>S</sub>)</b>	10 ... 30 V DC	
<b>Analogue signal</b>	4 ... 20 mA	
<b>max. input resistance of the input circuit</b>	200 Ohm (U <sub>S</sub> = 10 V), 1 kOhm (U <sub>S</sub> = 30 V)	
<b>Measuring range</b>	0 ... 360°	
<b>Max. error (25°C)</b>	0.2°	
<b>Resolution</b>	13 bit	
<b>Setting time</b>	max. 2 ms	
<b>Temperature coefficient</b>	0.1°/10 K	
<b>Current with scan error</b>	≤ 3.5 mA	
<b>Sensor component and current loop are galvanically isolated</b>		
<b>UL-certified</b>	File 224618	
<b>CE compliant acc. to</b>	EN 61000-6-2, EN 61000-6-4 and EN 61000-6-3	
<b>RoHS compliant acc. to</b>	EU-guideline 2002/95/EG	

1) For continuous operation max. 1500 min<sup>-1</sup>  
2) 80°C for shaft version and cable connection  
3) 70°C for hollow shaft version and cable connection

# Absolute Encoders - Singleturn

<b>Standard, optical</b>	<b>5850 / 5870 (Shaft / Hollow shaft)</b>	<b>Parallel, Analogue</b>
--------------------------	---	---------------------------

## Control inputs

### Switching levels of the control inputs

Supply voltage	5 V DC	10 ... 30 V DC
Switching level	low	≤ 1.7 V
	high	≥ 3.4 V
		≤ 4.5 V
		≥ 8.7 V

### Up/Down input to switch the counting direction

As a standard, absolute encoders deliver increasing code values when the shaft rotates clockwise (cw), when looking from the shaft side. When the shaft rotates counter-clockwise (ccw), the output delivers accordingly decreasing code values. The same applies to models with current interfaces. When the shaft rotates clockwise, the output delivers increasing current values, and decreasing values when it rotates counter-clockwise.

As long as the Up/Down input receives the corresponding signal (high), this feature is reversed. Clockwise rotation will deliver decreasing code/current values while counter-clockwise rotation will deliver increasing code/current values.

The response time is :

for 5 V DC supply voltage, 0.4 ms

for 10 ... 30 V DC supply voltage, 2 ms.

### SET input

This input is used to reset (zero) the encoder. A control pulse (high) sent to this input allows the current position value to be saved as the new zero position in the encoder.

For models equipped with a current interface, the analogue output (4 ... 20 mA) will be set accordingly to the value 4 mA.

Note : After applying power to the encoder and before activating the SET input, a count direction (cw or ccw) must be clearly defined on the Up/Down input!

The response time is :

for 5 V DC supply voltage, 0.4 ms

for 10 ... 30 V DC supply voltage, 2 ms.

### LATCH input

This input is used to "freeze" the current position value. The position value will be statically available on the parallel output as long as this input remains active (high).

The response time is :

for 5 V DC supply voltage, 140 µs,

for 10 ... 30 V DC supply voltage, 200 µs.

## Terminal assignment

Parallel interface up to 13 bit and max. 2 options

Signal	0V	+U <sub>B</sub>	1	2	3	4	5	6	7	8	9	10	11	12	13	ST/VR	VR/LH		⊥
Cable colour	WH	BN	GN	YE	GY	PK	BU	RD	BK	VT	GY PK	RD BU	WH GN	BN GN	WH YE	YE BN	WH GY		
Pin	1	2	3	4	5	6	7	8	9	10	11	12	13	14	15	16	17		PH

Parallel interface, with cable, 14 bit and max. 2 options

Signal	0V	+U <sub>B</sub>	1	2	3	4	5	6	7	8	9	10	11	12	13	ST/VR	VR/LH	14	⊥
Cable colour	WH	BN	GN	YE	GY	PK	BU	RD	BK	VT	GY PK	RD BU	WH GN	BN GN	WH YE	YE BN	WH GY	GY BN	

Parallel interface, with connector, 14 bit and 1 option

Signal	0V	+U <sub>B</sub>	1	2	3	4	5	6	7	8	9	10	11	12	13	ST/VR/LH	14	⊥
Pin	1	2	3	4	5	6	7	8	9	10	11	12	13	14	15	16	17	PH

Analogue interface 4 ... 20 mA with 12-pin connector

Signal	0V	+U <sub>B</sub>	—	—	I+	I-	ST	VR					⊥						
Cable colour	WH	BN	GN	YE	GY	PK	BU	RD	BK	VT	GY PK	RD BU							
Pin	1	2	3	4	5	6	7	8	9	10	11	12	PH						

Sig.: 1 = MSB; 2 = MSB-1; 3 = MSB-2 etc.

ST: SET input

Parallel: The current position value is stored as new zero position.  
4 ... 20 mA: measured value set to 4 mA

VR: Up/down input. As long as this input is active, decreasing code values are transmitted when shaft turning

+I: Current loop input

-I: Current loop output

LH: LATCH input. Active HIGH. The current position is saved and is statically available at the output.

PH: Plug housing

**Isolate unused outputs before initial start-up.**

## Top view of mating side, male contact base

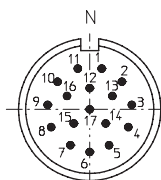

M23 connector, 17 pin (parallel)

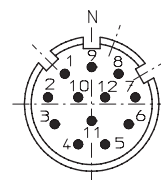

M23 connector, 12 pin (4... 20 mA)

# Absolute Encoders - Singleturn

Standard, optical

5850 / 5870 (Shaft / Hollow shaft)

Parallel, Analogue

## Dimensions shaft version

Clamping flange with shaft  $\varnothing$  10 mm

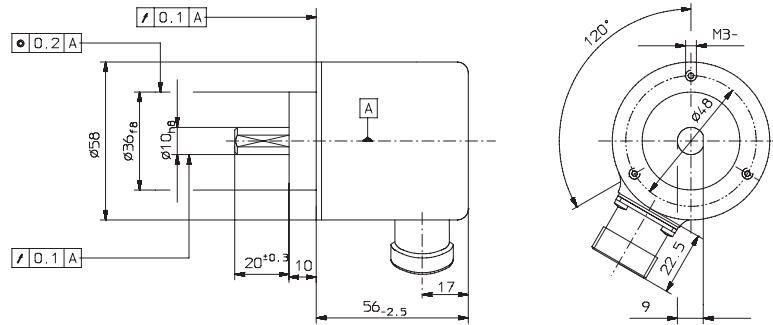

Synchro flange with shaft  $\varnothing$  6 mm

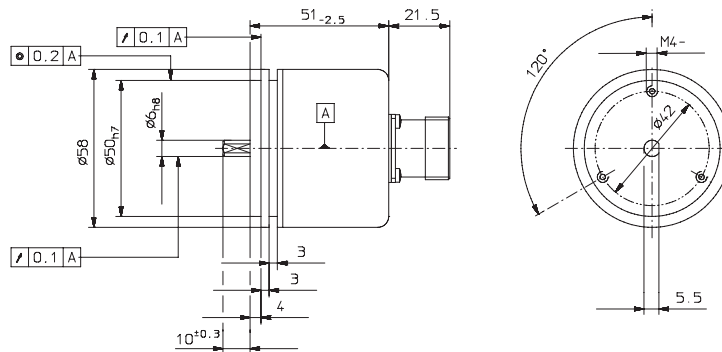

## Dimensions hollow shaft version

With torque stop set  
Flange type 1 and 2

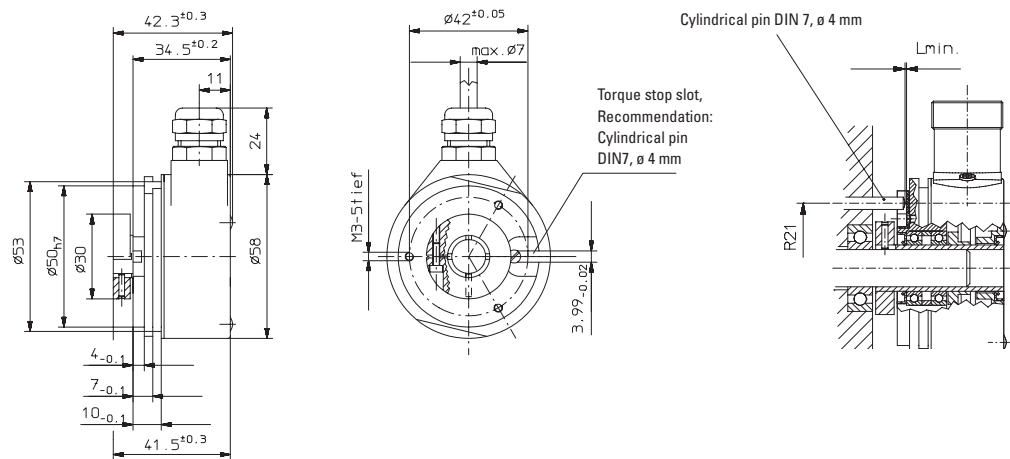

With stator coupling  
Flange Typ 3 and 4

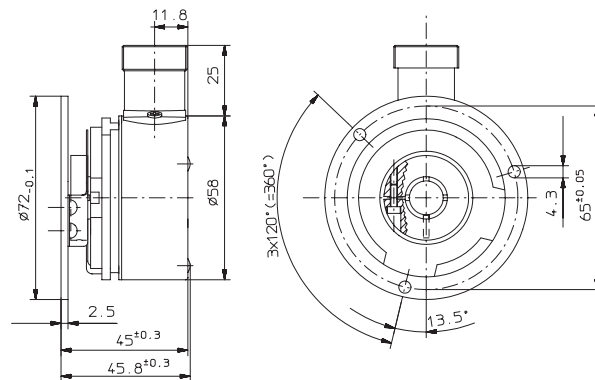

Note:  
Minimum insertion depth 1.5 x D (hollow shaft)

## Mounting advice

- 1) The flanges and shafts of the encoder and drive should not both be rigidly coupled together at the same time!
- 2) When mounting a hollow shaft encoder, we recommend using the torque stop pin or a stator coupling.
- 3) When mounting the encoder ensure that the dimension Lmin. is larger than the maximum axial play of the drive. Otherwise there is a danger that the device could mechanically seize up.