

ATM60/ATM90: Absolute Encoders Multiturn extremely robust and exceptionally reliable.

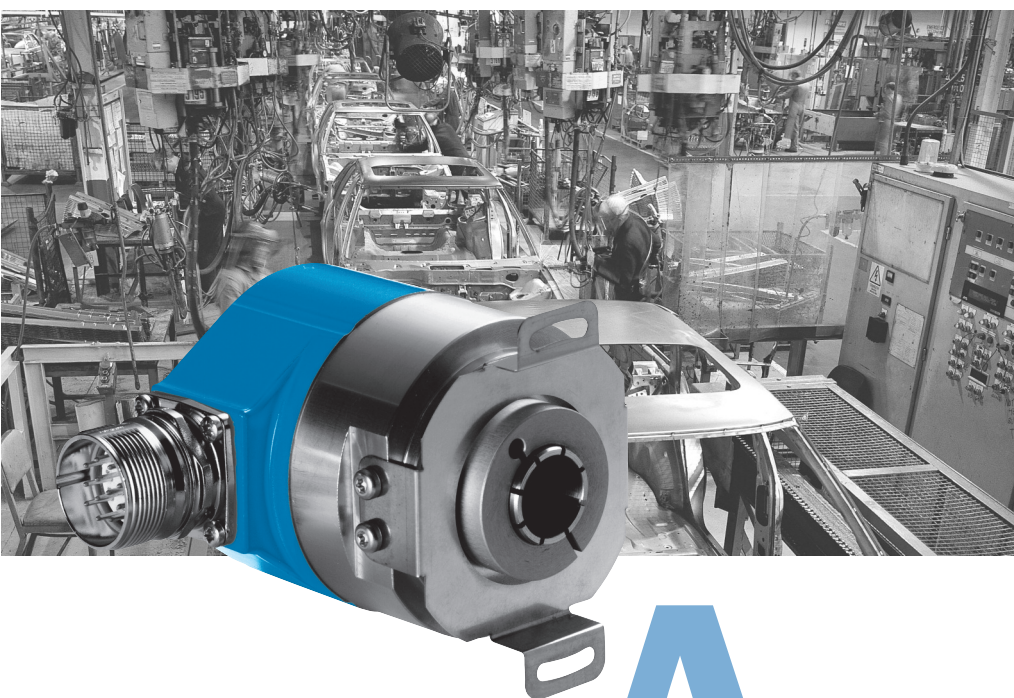

With SSI or RS 422 configuration interface, Profibus, CANopen or DeviceNet field bus technology, all current interfaces suitable for the high requirements in automation technology are also available.

Thanks to this wide variety of products, there are numerous possible uses, for example in:

- machine tools
- textile machines
- woodworking machines
- packaging machines
- wind turbines

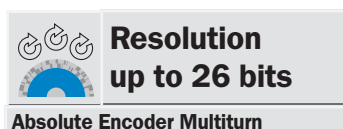

A All multiturn designs are implemented using mechanical gearboxes. These supply the revolution information very reliably and free from interference.

Whether with face mount flange, servo flange, blind or through hollow shaft with connector or cable outlet, the absolute encoders multiturn from SICK-STEGMANN will meet virtually any application profile.

SICK | STEGMANN



Resolution up to 26 bits

Absolute Encoder Multiturn

- Extremely robust
- SSI and RS 422 configuration interface
- Electronically adjustable, resolution adjustable
- Highly shock- and vibration-proof
- High degree of protection IP 67

Dimensional drawing face mount flange, connector radial

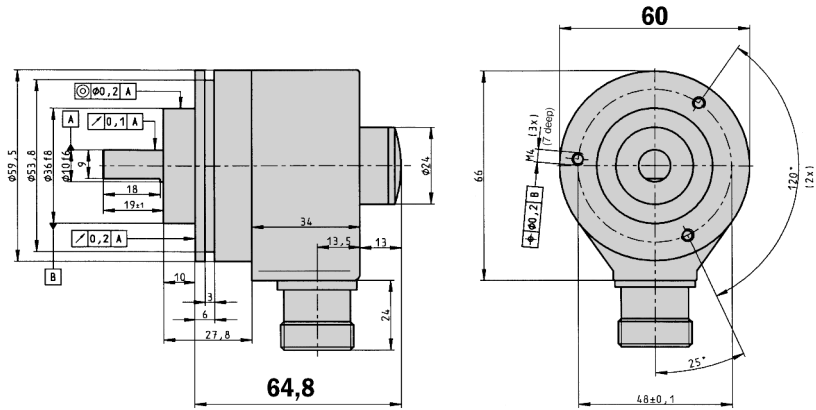

General tolerances according DIN ISO 2768-mk

Dimensional drawing face mount flange, cable radial

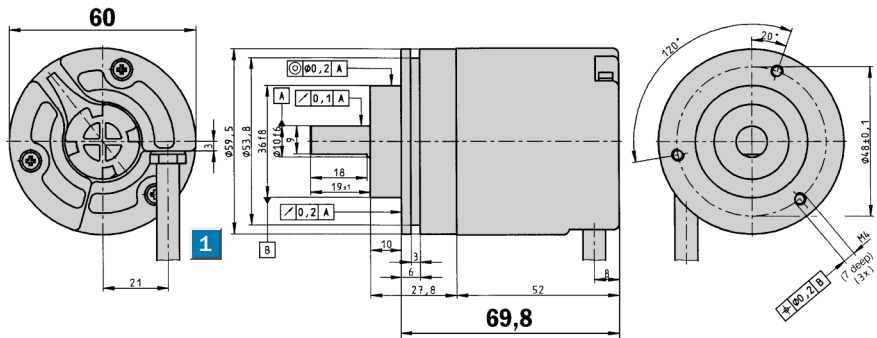

1 = bending radius min. 40 mm

General tolerances according DIN ISO 2768-mk

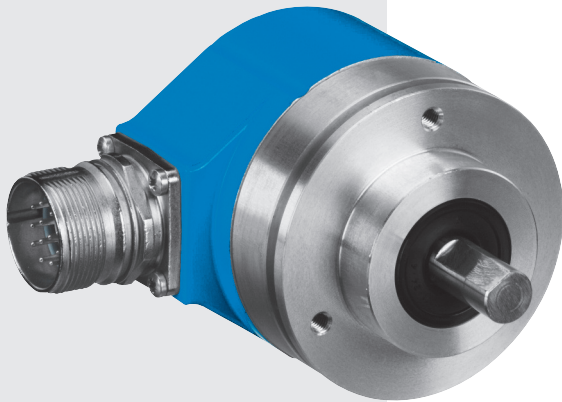

PIN and wire allocation

PIN	Signal	Wire colours (cable outlet)	Explanation
1	GND	blue	Earth connection
2	Data +	white	Signal line
3	Clock +	yellow	Signal line
4	R x D +	grey	RS 422 programming line
5	R x D -	green	RS 422 programming line
6	T x D +	pink	RS 422 programming line
7	T x D -	black	RS 422 programming line
8	U _s	red	Supply voltage
9	SET	orange	Electronical adjustment
10	Data -	brown	Signal line
11	Clock -	lilac	Signal line
12	CW/CCW	orange/black	Counting sequence when turning
	Screen		Housing potential

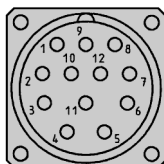

View of the connector M23 fitted to the encoder body

CW/CCW Forward/reverse:
This input programs the counting direction of the encoder. If not connected, this input is "HIGH". If the encoder shaft, as viewed on the drive shaft, rotates in the clockwise direction, it counts in an increasing sequence. If it should count upwards when the shaft rotates in the anti-clockwise direction, this connection must be connected permanently to "LOW" level (zero volts).

SET This input activates the electronic zero set.
When the SET line is connected to U_s for more than 100 ms, the current mechanical position is assigned the value 0 or the pre-programmed SET-value.

Accessories

- Connection systems
- Mounting systems
- Programming tool
- Adaptor modules



Technical data according to DIN 32878		ATM60 SSI	Flange type							
			face m.							
Solid shaft	10 mm									
Mass ¹⁾	Approx. 0.5 kg									
Moment of inertia of the rotor	35 gcm ²									
Programmable code type	Gray/binary									
Programmable code direction	CW/CCW									
Measuring step	0.043°									
Max. number of steps per revolution	8,192									
Max. number of revolutions	8,192									
Error limits	± 0.25°									
Repeatability	0.1°									
Operating speed	6,000 min ⁻¹									
Position forming time	0.15 ms									
Max. angular acceleration	5 x 10 ⁵ rad/s ²									
Operating torque										
with shaft seal	1.8 Ncm									
without shaft seal ²⁾	0.3 Ncm									
Start up torque										
with shaft seal	2.5 Ncm									
without shaft seal ²⁾	0,5 Ncm									
Max. shaft loading										
radial	300 N									
axial	50 N									
Bearing lifetime	3.6 x 10 ⁹ revolutions									
Working temperature range	- 20 ... + 85 °C									
Storage temperature range	- 40 ... + 100 °C									
Permissible relative humidity	98 %									
EMC ³⁾										
Resistance										
to shocks ⁴⁾	100/6 g/ms									
to vibration ⁵⁾	20/10 ... 2000 g/Hz									
Protection class acc. IEC 60529										
with shaft seal	IP 67									
without shaft seal ⁶⁾	IP 43									
without shaft seal ⁷⁾	IP 65									
Operating voltage range (Us)	10 ... 32 V									
Power consumption	0.8 W									
Initialisation time ⁸⁾	1050 ms									
Signals ⁹⁾										
Interface signals										
Clock +, Clock -, Data +, Data - ¹⁰⁾	SSI max. clock frequency 1 MHz i.e. min. duration of low level (clock +): 500 ns									
T x D +, T x D -, R x D +, R x D -	RS 422									
SET (electronic adjustment)	H-active (L ≙ 0 - 4.7 V; H ≙ 10 - U _s V)									
CW/CCW (steps sequence in direction of rotation)	L-active (L ≙ 0 - 1.5 V; H ≙ 2.0 - U _s V)									

¹⁾ For an encoder with connector outlet

²⁾ If the shaft seal has been removed by the customer

³⁾ To DIN EN 61000-6-2 and DIN EN 61000-6-3

⁴⁾ To DIN EN 60068-2-27

⁵⁾ To DIN EN 60068-2-6

⁶⁾ On encoder flange not sealed

⁷⁾ On encoder flange sealed

⁸⁾ From the moment the supply voltage is applied, this is the time which elapses before the data word can be correctly read in

⁹⁾ Carried by 12 way connector, potential-free with respect to housing, or 12 core cable

¹⁰⁾ For higher clock frequencies, choose synchronous SSI

Order information

ATM60 face mount flange solid shaft; U_s 10 ... 32 V; SSI

1 Configuration ex-works: 4,096 steps x 4,096 revolutions, Gray-Code, Set = 0

Type	Part no.	Explanation
ATM60-A4A12X12	1 030 001	Connector M23, 12 pin
ATM60-A4K12X12	1 030 002	Cable 1.5 m
ATM60-A4L12X12	1 030 003	Cable 3 m
ATM60-A4M12X12	1 030 004	Cable 5 m
ATM60-A4N12X12	1 032 915	Cable 10 m

1 Other configurations on request



Resolution up to 26 bits

Absolute Encoder Multiturn

- Extremely robust
- SSI and RS 422 configuration interface
- Electronically adjustable, resolution adjustable
- Highly shock- and vibration-proof
- High degree of protection IP 67

Dimensional drawing servo flange, connector radial

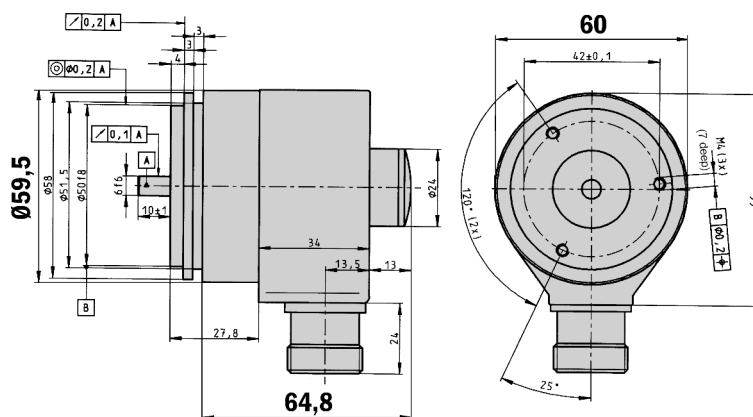

General tolerances according DIN ISO 2768-mk

Dimensional drawing servo flange, cable radial

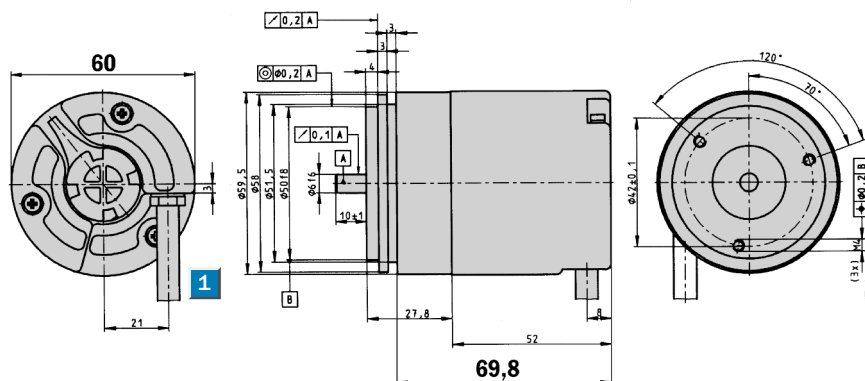

1 = bending radius min. 40 mm

General tolerances according DIN ISO 2768-mk

PIN and wire allocation

PIN	Signal	Wire colours (cable outlet)	Explanation
1	GND	blue	Earth connection
2	Data +	white	Signal line
3	Clock +	yellow	Signal line
4	R x D +	grey	RS 422 programming line
5	R x D -	green	RS 422 programming line
6	T x D +	pink	RS 422 programming line
7	T x D -	black	RS 422 programming line
8	U _s	red	Supply voltage
9	SET	orange	Electronical adjustable
10	Data -	brown	Signal line
11	Clock -	lilac	Signal line
12	CW/CCW	orange/black	Counting sequence when turning
	Screen		Housing potential

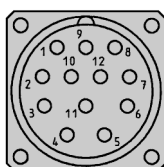

View of the connector M23 fitted to the encoder body

CW/CCW Forward/reverse:
This input programs the counting direction of the encoder. If not connected, this input is "HIGH". If the encoder shaft, as viewed on the drive shaft, rotates in the clockwise direction, it counts in an increasing sequence. If it should count upwards when the shaft rotates in the anti-clockwise direction, this connection must be connected permanently to "LOW" level (zero volts).

SET This input activates the electronic zero set.
When the SET line is connected to U_s for more than 100 ms, the current mechanical position is assigned the value 0 or the pre-programmed SET-value.

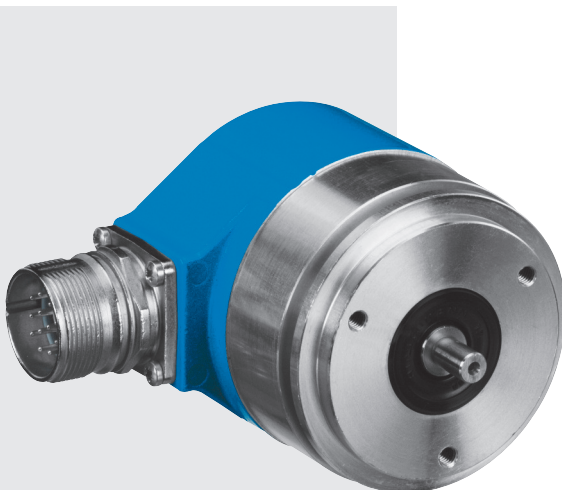

Accessories

- Connection systems
- Mounting systems
- Programming tool
- Adaptor modules

Technical data according to DIN 32878		ATM60 SSI	Flange type						
			servo						
Solid shaft	6 mm								
Mass ¹⁾	Approx. 0.5 kg								
Moment of inertia of the rotor	35 gcm ²								
Programmable code type	Gray/binary								
Programmable code direction	CW/CCW								
Measuring step	0.043°								
Max. number of steps per revolution	8,192								
Max. number of revolutions	8,192								
Error limits	± 0.25°								
Repeatability	0.1°								
Operating speed	6,000 min ⁻¹								
Position forming time	0.15 ms								
Max. angular acceleration	5 x 10 ⁵ rad/s ²								
Operating torque									
with shaft seal	1.8 Ncm								
without shaft seal ²⁾	0.3 Ncm								
Start up torque									
with shaft seal	2.5 Ncm								
without shaft seal ²⁾	0.5 Ncm								
Max. shaft loading									
radial	300 N								
axial	50 N								
Bearing lifetime	3.6 x 10 ⁹ revolutions								
Working temperature range	- 20 ... + 85 °C								
Storage temperature range	- 40 ... + 100 °C								
Permissible relative humidity	98 %								
EMC ³⁾									
Resistance									
to shocks ⁴⁾	100/6 g/ms								
to vibration ⁵⁾	20/10 ... 2000 g/Hz								
Protection class acc. IEC 60529									
with shaft seal	IP 67								
without shaft seal ⁶⁾	IP 43								
without shaft seal ⁷⁾	IP 65								
Operating voltage range (Us)	10 ... 32 V								
Power consumption	0.8 W								
Initialisation time ⁸⁾	1050 ms								
Signals ⁹⁾									
Interface signals									
Clock +, Clock -, Data +, Data - ¹⁰⁾	SSI max. clock frequency 1 MHz i.e. min. duration of low level (clock +): 500 ns								
T x D +, T x D -, R x D +, R x D -	RS 422								
SET (electronic adjustment)	H-active (L ≙ 0 - 4.7 V; H ≙ 10 - U _s V)								
CW/CCW (steps sequence in direction of rotation)	L-active (L ≙ 0 - 1.5 V; H ≙ 2.0 - U _s V)								

¹⁾ For an encoder with connector outlet

²⁾ If the shaft seal has been removed by the customer

³⁾ To DIN EN 61000-6-2 and DIN EN 61000-6-3

⁴⁾ To DIN EN 60068-2-27

⁵⁾ To DIN EN 60068-2-6

⁶⁾ On encoder flange not sealed

⁷⁾ On encoder flange sealed

⁸⁾ From the moment the supply voltage is applied, this is the time which elapses before the data word can be correctly read in

⁹⁾ Carried by 12 way connector, potential-free with respect to housing, or 12 core cable

¹⁰⁾ For higher clock frequencies, choose synchronous SSI

Order information

ATM60 servo flange solid shaft; U_s 10 ... 32 V; SSI

1 Configuration ex-works: 4,096 steps x 4,096 revolutions, Gray-Code, Set = 0

Type	Part no.	Explanation
ATM60-A1A12X12	1 030 005	Connector M23, 12 pin
ATM60-A1K12X12	1 030 006	Cable 1.5 m
ATM60-A1L12X12	1 030 007	Cable 3 m
ATM60-A1M12X12	1 030 008	Cable 5 m
ATM60-A1N12X12	1 032 925	Cable 10 m

1 Other configurations on request



Resolution up to 26 bits

Absolute Encoder Multiturn

- Extremely robust
- SSI and RS 422 configuration interface
- Electronically adjustable, resolution adjustable
- Highly shock- and vibration-proof
- High degree of protection IP 67

Dimensional drawing blind hollow shaft, connector radial

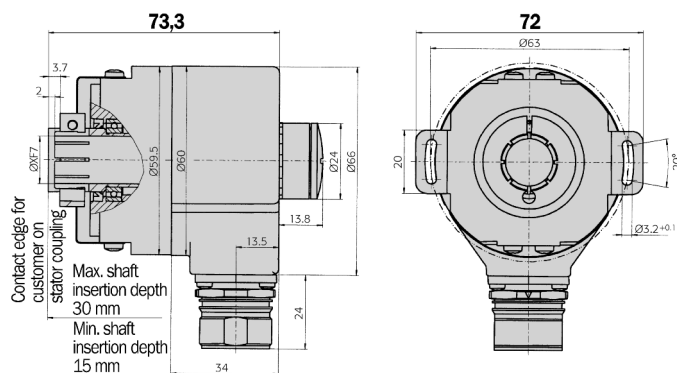

General tolerances according DIN ISO 2768-mk

Dimensional drawing blind hollow shaft, cable radial

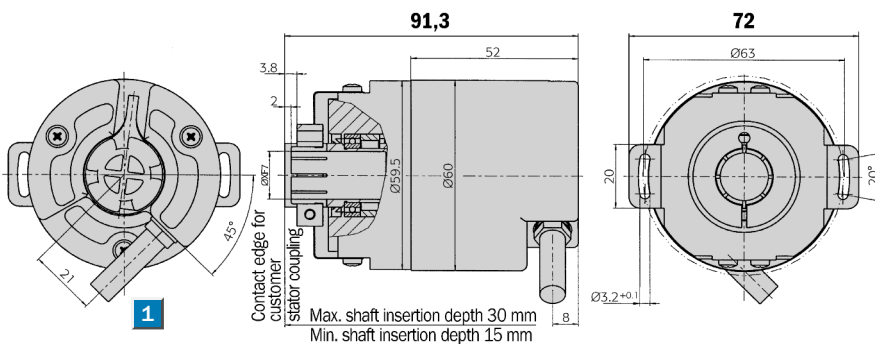

General tolerances according DIN ISO 2768-mk

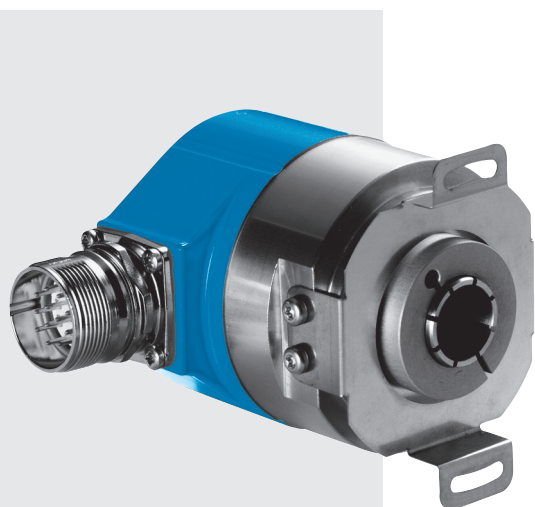

PIN and wire allocation

PIN	Signal	Wire colours (cable outlet)	Explanation
1	GND	blue	Earth connection
2	Data +	white	Signal line
3	Clock +	yellow	Signal line
4	R x D +	grey	RS 422 programming line
5	R x D -	green	RS 422 programming line
6	T x D +	pink	RS 422 programming line
7	T x D -	black	RS 422 programming line
8	U _s	red	Supply voltage
9	SET	orange	Electronical adjustment
10	Data -	brown	Signal line
11	Clock -	lilac	Signal line
12	CW/CCW	orange/black	Counting sequence when turning
	Screen		Housing potential

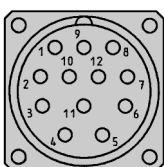

View of the connector M23 fitted to the encoder body

CW/CCW Forward/reverse:
This input programs the counting direction of the encoder. If not connected, this input is "HIGH". If the encoder shaft, as viewed on the drive shaft, rotates in the clockwise direction, it counts in an increasing sequence. If it should count upwards when the shaft rotates in the anti-clockwise direction, this connection must be connected permanently to "LOW" level (zero volts).

SET This input activates the electronic zero set.
When the SET line is connected to U_s for more than 100 ms, the current mechanical position is assigned the value 0 or the pre-programmed SET-value.

Accessories

- Connection systems
- Collets
- Programming tool
- Adaptor modules



Technical data according to DIN 32878		ATM60 SSI	Flange type						
			blind						
1 Hollow shaft diameter	6, 8, 10, 12, 15 mm, 1/4", 3/8", 1/2"								
Mass ¹⁾	Approx. 0.4 kg								
Moment of inertia of the rotor	55 gcm ²								
Programmable code type	Gray/binary								
Programmable code direction	CW/CCW								
Measuring step	0.043°								
Max. number of steps per revolution	8,192								
Max. number of revolutions	8,192								
Error limits	± 0.25°								
Repeatability	0.1°								
Operating speed	3,000 min ⁻¹								
Position forming time	0.15 ms								
Max. angular acceleration	5 x 10 ⁵ rad/s ²								
Operating torque	0.8 Ncm ²⁾								
Start up torque	1.2 Ncm ²⁾								
Permissible shaft movement of the drive element									
radial static/dynamic	± 0.3/± 0.1 mm								
axial static/dynamic	± 0.5/± 0.2 mm								
Bearing lifetime	3.6 x 10 ⁹ revolutions								
Working temperature range	- 20 ... + 85 °C								
Storage temperature range	- 40 ... + 100 °C								
Permissible relative humidity	98 %								
EMC ³⁾									
Resistance									
to shocks ⁴⁾	100/6 g/ms								
to vibration ⁵⁾	20/10 ... 2000 g/Hz								
Protection class acc. IEC 60529 ²⁾	IP 67								
without shaft seal ⁶⁾	IP 43								
Operating voltage range (Us)	10 ... 32 V								
Power consumption	0.8 W								
Initialisation time ⁷⁾	1050 ms								
Signals ⁸⁾									
Interface signals									
Clock +, Clock -, Data +, Data - ⁹⁾	SSI max. clock frequency 1 MHz i.e. min. duration of low level (clock +): 500 ns								
T x D +, T x D -, R x D +, R x D -	RS 422								
SET (electronic adjustment)	H-active (L ≙ 0 - 4.7 V; H ≙ 10 - Us V)								
CW/CCW ¹⁰⁾	L-active (L ≙ 0 - 1.5 V; H ≙ 2.0 - Us V)								

¹⁾ For an encoder with connector outlet

²⁾ With shaft seal

³⁾ To DIN EN 61000-6-2 and DIN EN 61000-6-3

⁴⁾ To DIN EN 60068-2-27

⁵⁾ To DIN EN 60068-2-6

⁶⁾ On encoder flange not sealed

⁷⁾ From the moment the supply voltage is applied, this is the time which elapses before the data word can be correctly read in.

⁸⁾ Carried by 12 way connector, potential-free with respect to housing, or 12 core cable

⁹⁾ For higher clock frequencies, choose synchronous SSI

¹⁰⁾ Step sequence in direction of rotation

2 Other configurations on request

Order information

ATM60 blind hollow shaft; Us 10 ... 32 V; SSI

2 Configuration ex-works: 4,096 steps x 4,096 revolutions, Gray-Code, Set = 0

Type	Part no.	Explanation
ATM60-AAA12X12	1 030 009	Connector M23, 12 pin
ATM60-AAK12X12	1 030 010	Cable 1.5 m
ATM60-AAL12X12	1 030 011	Cable 3 m
ATM60-AAM12X12	1 030 012	Cable 5 m
ATM60-AAN12X12	1 033 169	Cable 10 m

1 Attention: Please order the collet with required diameter separately

Type	Part no.	Shaft diameter
SPZ-006-AD-A	2 029 174	6 mm
SPZ-1E4-AD-A	2 029 175	1/4"
SPZ-008-AD-A	2 029 176	8 mm
SPZ-3E8-AD-A	2 029 177	3/8"
SPZ-010-AD-A	2 029 178	10 mm
SPZ-012-AD-A	2 029 179	12 mm
SPZ-1E2-AD-A	2 029 180	1/2"
SPZ-014-AD-A	2 048 863	14 mm

For 15 mm shaft diameter, collet is not needed



Resolution up to 26 bits

Absolute Encoder Multiturn

- Extremely robust
- SSI and RS 422 configuration interface
- Electronically adjustable, resolution adjustable
- Highly shock- and vibration-proof
- High degree of protection IP 65

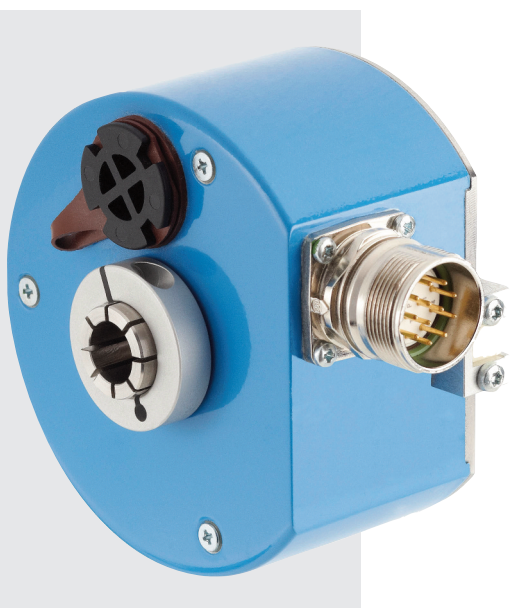

Accessories

- Connection systems
- Programming tool
- Adaptor modules

Dimensional drawing through hollow shaft; connector radial, cable radial

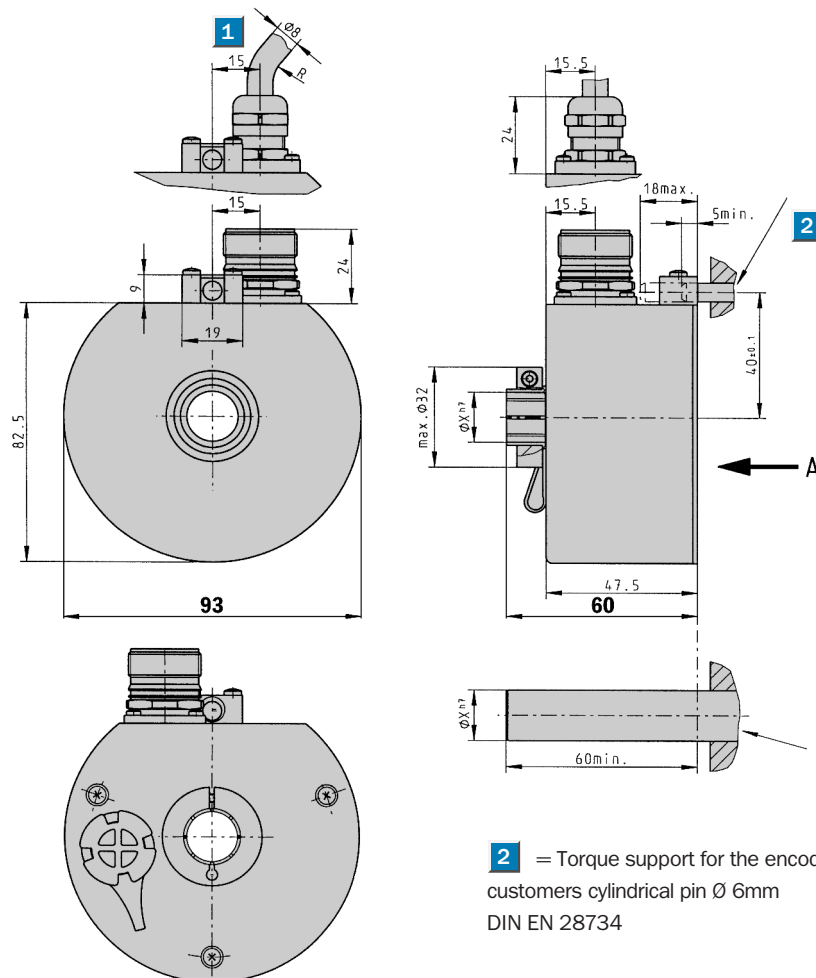

General tolerances according DIN ISO 2768-mk

PIN and wire allocation

PIN	Signal	Wire colours (cable outlet)	Explanation
1	GND	blue	Earth connection
2	Data +	white	Signal line
3	Clock +	yellow	Signal line
4	R x D +	grey	RS 422 programming line
5	R x D -	green	RS 422 programming line
6	T x D +	pink	RS 422 programming line
7	T x D -	black	RS 422 programming line
8	U_s	red	Supply voltage
9	SET	orange	Electronical adjustment
10	Data -	brown	Signal line
11	Clock -	lilac	Signal line
12	CW/CCW	orange/black	Counting sequence when turning
	Screen		Housing potential

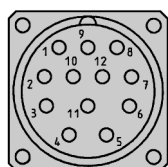

View of the connector M23 fitted to the encoder body

CW/CCW Forward/reverse:
This input programs the counting direction of the encoder. If not connected, this input is "HIGH". If the encoder shaft, as viewed on the drive shaft, rotates in the clockwise direction, it counts in an increasing sequence. If it should count upwards when the shaft rotates in the anti-clockwise direction, this connection must be connected permanently to "LOW" level (zero volts).

SET This input activates the electronic zero set.
When the SET line is connected to U_s for more than 100 ms, the current mechanical position is assigned the value 0 or the pre-programmed SET-value.

Technical data according to DIN 32878		ATM90 SSI	Flange type
			through
Hollow shaft diameter	12, 16 mm, 1/2"		
Mass ¹⁾	Approx. 0.8 kg		
Moment of inertia of the rotor	152.77 gcm ²		
Programmable code type	Gray/binary		
Programmable code direction	CW/CCW		
Measuring step	0.043°		
Max. number of steps per revolution	8,192		
Max. number of revolutions	8,192		
Error limits	± 0.25°		
Repeatability	0.1°		
Operating speed	2,000 min ⁻¹		
Position forming time	0.15 ms		
Max. angular acceleration	5 x 10 ⁵ rad/s ²		
Operating torque	0.4 Ncm		
Start up torque	0.5 Ncm		
Bearing lifetime	3.6 x 10 ⁹ revolutions		
Working temperature range	- 20 ... + 70 °C		
Storage temperature range	- 40 ... + 100 °C		
Permissible relative humidity	98 %		
EMC ²⁾			
Resistance			
to shocks ³⁾	100/6 g/ms		
to vibration ⁴⁾	20/10 ... 2000 g/Hz		
Protection class acc. IEC 60529			
with shaft seal	IP 65		
Operating voltage range (Us)	10 ... 32 V		
Power consumption	0.8 W		
Initialisation time ⁵⁾	1050 ms		
Signals ⁶⁾			
Interface signals			
Clock +, Clock -, Data +, Data - ⁷⁾	SSI max. clock frequency 1 MHz i.e. min. duration of low level (clock +): 500 ns		
T x D +, T x D -, R x D +, R x D -	RS 422		
SET (electronic adjustment)	H-active (L ≙ 0 - 4.7 V; H ≙ 10 - U _s V)		
CW/CCW ⁸⁾	L-active (L ≙ 0 - 0.9 V; H ≙ 1.9 - U _s V)		

¹⁾ For an encoder with connector outlet

²⁾ To DIN EN 61000-6-2 and DIN EN 61000-6-3

³⁾ To DIN EN 60068-2-27

⁴⁾ To DIN EN 60068-2-6

⁵⁾ From the moment the supply voltage is applied, this is the time which elapses before the data word can be correctly read in

⁶⁾ Carried by 12 way connector, potential-free with respect to housing, or 12 core cable

⁷⁾ For higher clock frequencies, choose synchronous SSI

⁸⁾ Step sequence in direction of rotation

Order information

ATM90 through hollow shaft; U_s 10 ... 32 V; SSI

1 Configuration ex-works: 4,096 steps x 4,096 revolutions, Gray-Code, Set = 0

Type	Part no.	Explanation
ATM90-ATA12X12	1 030 030	Ø12 mm, connector M23, 12 pin
ATM90-ATK12X12	1 030 031	Ø12 mm, cable 1.5 m
ATM90-ATL12X12	1 030 032	Ø12 mm, cable 3 m
ATM90-ATM12X12	1 030 033	Ø12 mm, cable 5 m
ATM90-AUA12X12	1 030 034	Ø ¹ / ₂ " , connector M23, 12 pin
ATM90-AUK12X12	1 030 035	Ø ¹ / ₂ " , cable 1.5 m
ATM90-AUL12X12	1 030 036	Ø ¹ / ₂ " , cable 3 m
ATM90-AUM12X12	1 030 037	Ø ¹ / ₂ " , cable 5 m
ATM90-AXA12X12	1 030 038	Ø16 mm, connector M23, 12 pin
ATM90-AXK12X12	1 030 039	Ø16 mm, cable 1.5 m
ATM90-AXL12X12	1 030 040	Ø16 mm, cable 3 m
ATM90-AXM12X12	1 030 041	Ø16 mm, cable 5 m

1 Other configurations on request



**Resolution
up to 26 bits**

Absolute Encoder Multiturn

- Extremely robust
- RS 485 bus coupling to Profibus DP Specification
- Electronically adjustable, configuration adjustable
- Highly shock- and vibration-proof
- High degree of protection IP 67

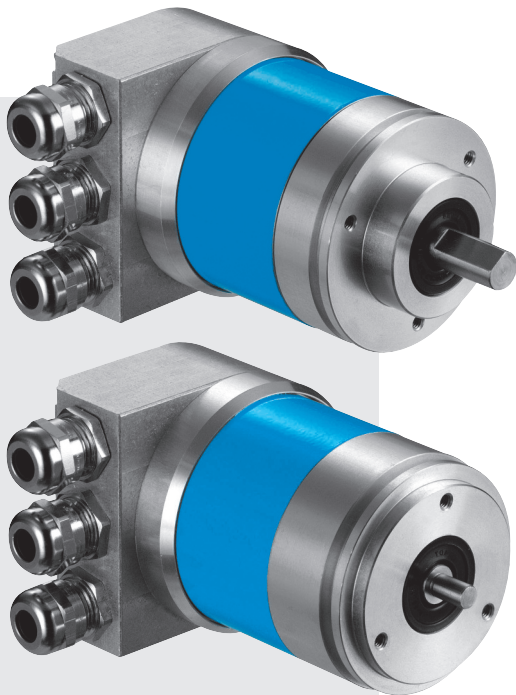

Accessories

- Bus adaptor
- Mounting systems

Dimensional drawing face mount flange

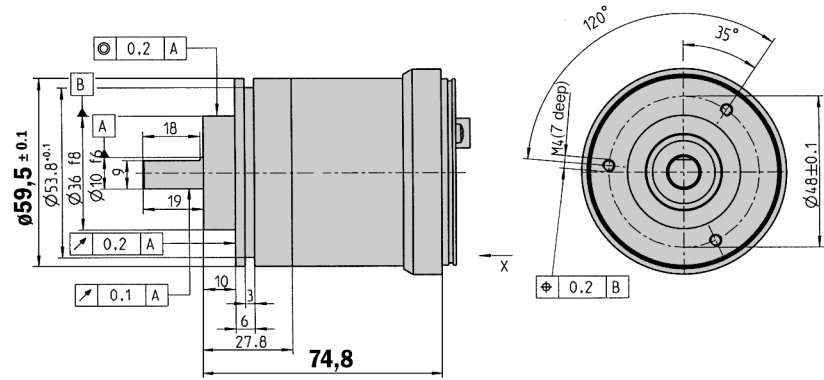

General tolerances according DIN ISO 2768-mk

Dimensional drawing servo flange

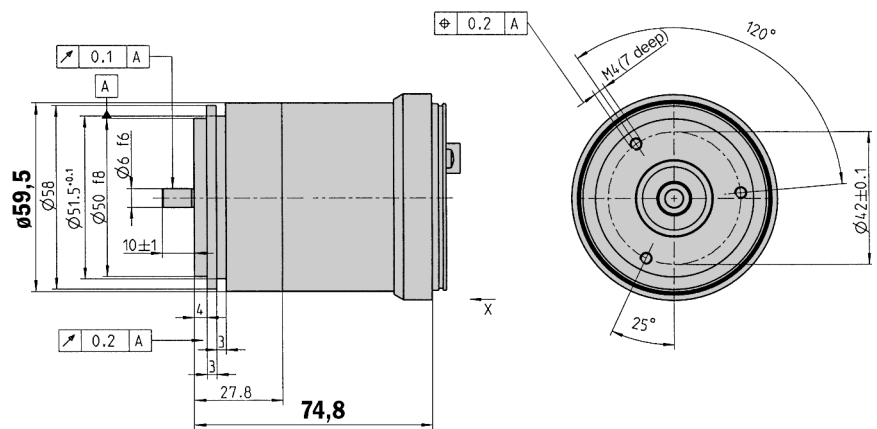

General tolerances according DIN ISO 2768-mk

1 PIN and wire allocation for Profibus adaptor

Terminal strip	Connector 4 pin	Connector 5 pin	Conn. female 5 pin	Signal	Explanation
1	1	–	–	U_s (24 V)	Supply voltage 10 ... 32 V
2	3	–	–	0 V (GND)	Ground (0 V)
3	–	–	4	B	Profibus DP B line (out)
4	–	–	2	A	Profibus DP A line (out)
5	–	4	–	B	Profibus DP B line (in)
6	–	2	–	A	Profibus DP A line (in)
7	–	–	1	2P5 ¹⁾	+ 5 V (DC isolated)
8	–	–	3	2M ¹⁾	0 V (DC isolated)
9	–	–	–	RTS ²⁾	Request To Send
–	2	1	–	N. C.	–
–	4	3	–	N. C.	–
–	–	5	5	Screen	Housing potential

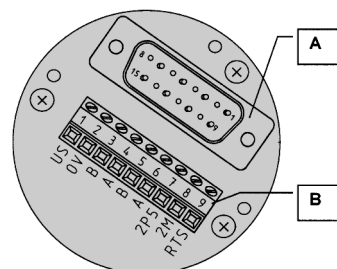

A Internal plug connection to the encoder
B External connection to the bus

¹⁾ Use for external bus termination or to supply the transmitter/receiver of an optical transmission link.

²⁾ Signal is optional, used to detect the direction of an optical connection.

1 Encoders with a Profibus adaptor have a terminal strip for connecting the bus and supply lines. In order to connect the lines, the Profibus adaptor is unscrewed from the complete device. The figure shows the pin allocation within the bus connection.

Technical data according to DIN 32878		ATM60 Profibus		Flange type							
		face m.	servo								
Solid shaft	10 mm										
	6 mm										
Mass	Approx. 0.59 kg										
Moment of inertia of the rotor	35 gcm ²										
Measuring step	0.043°										
Max. number of steps per revolution	8,192										
Max. number of revolutions	8,192										
Error limits	± 0.25°										
Repeatability	0.1°										
Operating speed	6,000 min ⁻¹										
Position forming time	0.15 ms										
Max. angular acceleration	5 x 10 ⁵ rad/s ²										
Operating torque											
with shaft seal	1.8 Ncm										
without shaft seal ¹⁾	0.3 Ncm										
Start up torque											
with shaft seal	2.5 Ncm										
without shaft seal ²⁾	0.5 Ncm										
Max. shaft loading											
radial	300 N										
axial	50 N										
Bearing lifetime	3.6 x 10 ⁹ revolutions										
Working temperature range	- 20 ... + 80 °C										
Storage temperature range	- 40 ... + 125 °C										
Permissible relative humidity	98 %										
EMC ²⁾											
Resistance											
to shocks ³⁾	100/6 g/ms										
to vibration ⁴⁾	20/10 ... 2000 g/Hz										
Protection class acc. IEC 60529											
with shaft seal	IP 67										
without shaft seal ⁵⁾	IP 43										
without shaft seal ⁶⁾	IP 66										
Operating voltage range (Us)	10 ... 32 V										
Power consumption	2.0 W										
Initialisation time ⁷⁾	1250 ms										
Bus Interface Profibus DP											
Electrical interface ⁸⁾	RS 485										
Protocol	Profile for Encoders (07 _{hex}) – Class 2										
Address setting (node number)	0 ... 127 (DIP switches or protocol)										
Data transmission rate (Baudrate)	9.6 kBaud – 12 MBaud ⁹⁾										
Electronic adjustment (Number SET)	Via PRESET push button or protocol										
Status information	Operation (LED green), bus activity (LED red)										
Bus termination	Via DIP switches ¹⁰⁾										
Electrical connection	Bus adaptor with screw fixing (x3)										

¹⁾ If the shaft seal has been removed by the customer

²⁾ To DIN EN 61000-6-2 and DIN EN 61000-6-3

³⁾ To DIN EN 60068-2-27

⁴⁾ To DIN EN 60068-2-6

⁵⁾ On encoder flange not sealed

⁶⁾ On encoder flange sealed

⁷⁾ From the moment the supply voltage is applied, this is the time which elapses before the data word can be correctly read in

⁸⁾ To EN 50 170-2 (DIN 19245 part 1-3) DC isolated via opto-couplers

⁹⁾ Automatic detection

¹⁰⁾ Should only be connected in the final device

Order information

ATM60 Profibus face mount flange and servo flange solid shaft; U_s 10 ... 32 V

Type	Part no.	Explanation
ATM60-P4H13X13	1 030 013	Face mount fl., solid shaft Ø 10 mm
ATM60-P1H13X13	1 030 014	Servo flange, solid shaft Ø 6 mm

Attention: Please order the Profibus adaptor separately (see page 14)



Resolution up to 26 bits

Absolute Encoder Multiturn

- Extremely robust
- RS 485 bus coupling to Profibus DP Specification
- Electronically adjustable, resolution adjustable
- Highly shock- and vibration-proof
- High degree of protection IP 67

Dimensional drawing blind hollow shaft

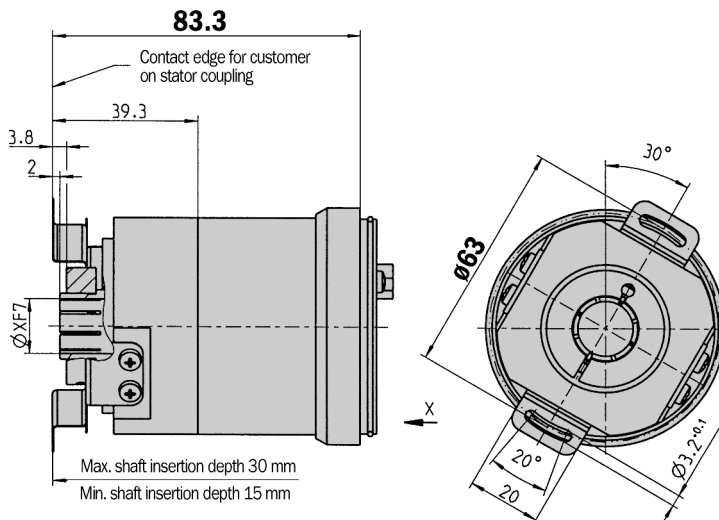

General tolerances according DIN ISO 2768-mk

1 PIN and wire allocation for Profibus adaptor

Terminal strip	Connector 4 pin	Connector 5 pin	Conn. female 5 pin	Signal	Explanation
1	1	–	–	U _s (24 V)	Supply voltage 10 ... 32 V
2	3	–	–	0 V (GND)	Ground (0 V)
3	–	–	4	B	Profibus DP B line (out)
4	–	–	2	A	Profibus DP A line (out)
5	–	4	–	B	Profibus DP B line (in)
6	–	2	–	A	Profibus DP A line (in)
7	–	–	1	2P5 ¹⁾	+ 5 V (DC isolated)
8	–	–	3	2M ¹⁾	0 V (DC isolated)
9	–	–	–	RTS ²⁾	Request To Send
–	2	1	–	N. C.	–
–	4	3	–	N. C.	–
–	–	5	5	Screen	Housing potential

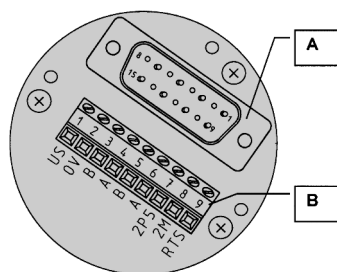

A Internal plug connection to the encoder
B External connection to the bus

- ¹⁾ Use for external bus termination or to supply the transmitter/receiver of an optical transmission link.
- ²⁾ Signal is optional, used to detect the direction of an optical connection.

1 Encoders with a Profibus adaptor have a terminal strip for connecting the bus and supply lines. In order to connect the lines, the Profibus adaptor is unscrewed from the complete device. The figure shows the pin allocation within the bus connection.

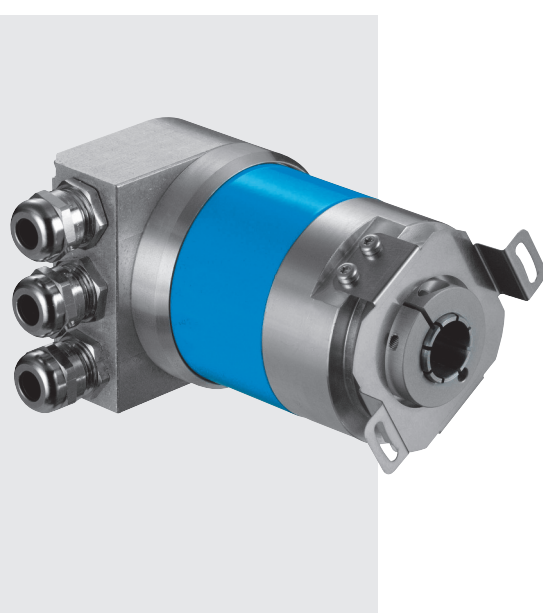

Accessories

Bus adaptor

Collets

Technical data according to DIN 32878		ATM60 Profibus		Flange type						
				blind						
1 Hollow shaft diameter	6, 8, 10, 12, 15 mm, 1/4", 3/8", 1/2"									
Mass	Approx. 0.59 kg									
Moment of inertia of the rotor	55 gcm ²									
Measuring step	0.043°									
Max. number of steps per revolution	8,192									
Max. number of revolutions	8,192									
Error limits	± 0,25°									
Repeatability	0.1°									
Operating speed	3,000 min ⁻¹									
Position forming time	0.25 ms									
Max. angular acceleration	5 x 10 ⁵ rad/s ²									
Operating torque	0.8 Ncm ¹⁾									
Start up torque	1.2 Ncm ¹⁾									
Permissible shaft movement of the drive element										
radial static/dynamic	± 0.3/± 0.1 mm									
axial static/dynamic	± 0.5/± 0.2 mm									
Bearing lifetime	3.6 x 10 ⁹ revolutions									
Working temperature range	- 20 ... + 80 °C									
Storage temperature range	- 40 ... + 125 °C									
Permissible relative humidity	98 %									
EMC ²⁾										
Resistance										
to shocks ³⁾	100/6 g/ms									
to vibration ⁴⁾	20/10 ... 2000 g/Hz									
Protection class acc. IEC 60529 ¹⁾	IP 67									
without shaft seal ⁵⁾	IP 43									
Operating voltage range (Us)	10 ... 32 V									
Power consumption	2.0 W									
Initialisation time ⁶⁾	1250 ms									
Bus Interface Profibus DP										
Electrical Interface ⁷⁾	RS 485									
Protocol	Profile for Encoders (07 _{hex}) – Class 2									
Address setting (node number)	0 ... 127 (DIP switches or protocol)									
Data transmission rate (baud rate)	9.6 kBaud – 12 MBaud ⁸⁾									
Electronic adjustment (number SET)	Via PRESET push button or protocol									
Status information	Operation (green LED), bus activity (red LED)									
Bus termination	Via DIP switches ⁹⁾									
Electrical connection	Bus connector with screw fixing (x3)									

¹⁾ With shaft seal
²⁾ To DIN EN 61000-6-2 and DIN EN 61000-6-3
³⁾ To DIN EN 60068-2-27
⁴⁾ To DIN EN 60068-2-6
⁵⁾ On encoder flange not sealed
⁶⁾ From the moment the supply voltage is applied, this is the time which elapses before the data word can be correctly read in
⁷⁾ To EN 50 170-2 (DIN 19245 part 1-3) DC isolated via opto-couplers
⁸⁾ Automatic detection
⁹⁾ Should only be connected in the final device

Order information		
ATM60 Profibus blind hollow shaft; U_s 10 ... 32 V		
Type	Part no.	Explanation
ATM60-PAH13X13	1 030 015	Blind hollow shaft
Attention: Please order the Profibus adaptor separately (see page 14)		

1 Attention: Please order the collet with required diameter separately		
Type	Part no.	Shaft diameter
SPZ-006-AD-A	2 029 174	6 mm
SPZ-1E4-AD-A	2 029 175	1/4"
SPZ-008-AD-A	2 029 176	8 mm
SPZ-3E8-AD-A	2 029 177	3/8"
SPZ-010-AD-A	2 029 178	10 mm
SPZ-012-AD-A	2 029 179	12 mm
SPZ-1E2-AD-A	2 029 180	1/2"
SPZ-014-AD-A	2 048 863	14 mm

For 15 mm shaft diameter, collet is not needed



Resolution up to 26 bits

Absolute Encoder Multiturn

- Extremely robust
- RS 485 bus coupling to Profibus DP Specification
- Electronically adjustable, resolution adjustable
- Highly shock- and vibration-proof
- High degree of protection IP 67

Dimensional drawing Profibus adaptor KA3

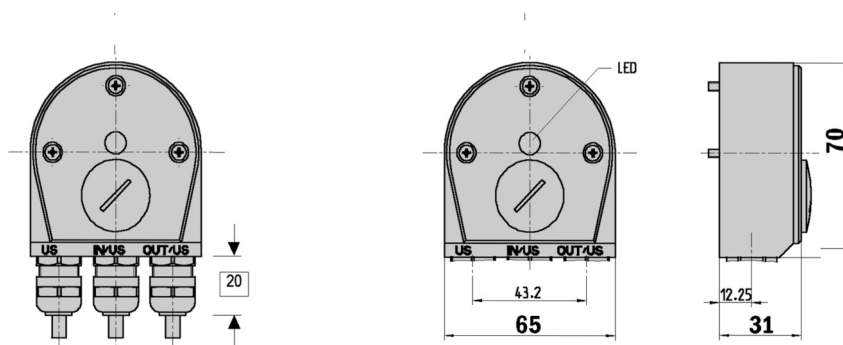

General tolerances according DIN ISO 2768-mk

Dimensional drawing Profibus adaptor SR3

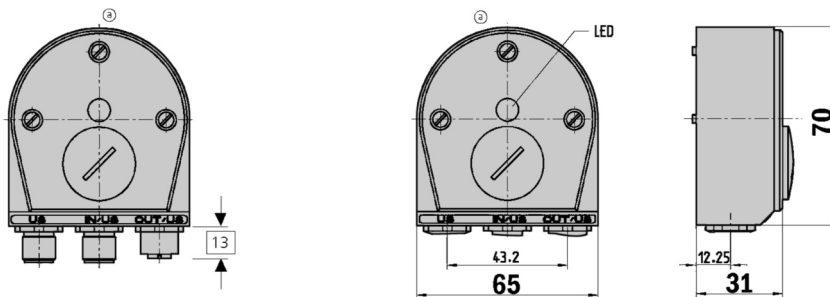

General tolerances according DIN ISO 2768-mk

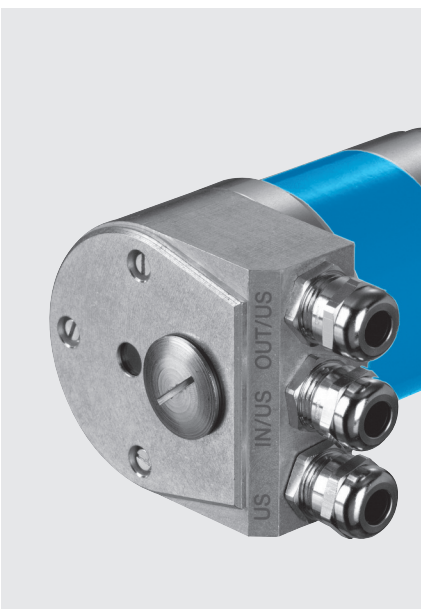

Order information

ATM60 Profibus adaptor

Type	Part no.	Explanation
AD-ATM60-KA3PR	2 029 225	Profibus adaptor KA3, 3 x PG
AD-ATM60-SR3PR	2 031 985	Profibus adaptor SR3, 1 x M12, 4 pin., 2 x M12, 5 pin.



Switch settings

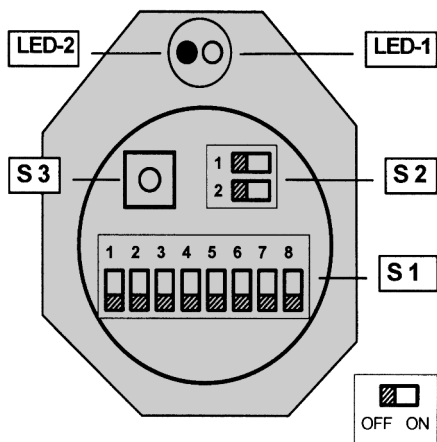

Switch settings

Access to the switches is gained by opening the removable screw cap (PG) on the rear of the bus adaptor. Use of the following elements.

S 1 (1-7)	Address setting (0 ... 127)
S 1 (8-8)	Counting direction (CW/CCW)
S 2	Bus termination
S 3	Preset push button (Number SET)

Status information via LEDs

LED-1	Operating voltage (green)
LED-2	Bus activity (red)

Implementation

DP Functionalities

in accordance with the Profibus DP basic functions.

DP services

- Data interchange (Write_Read_Data)
- Address allocation (Set_Slave_Address)
- Control commands (Global_Control)
- Read the inputs (Read_Inputs)
- Read the outputs (Read_Outputs)
- Read diagnostic data (Slave_Diagnosis)
- Send configuration data (Set_Param)
- Check configuration data (Chk_Config)

Communication

- Cyclic master – slave data traffic

Protective mechanisms

- Data transfer with HD = 4
- Time monitoring of the data traffic

Configuration

Settings in accordance with Encoder Profile

- Counting direction (CW, CCW)
- Class-2 functionality (ON, OFF)
- Scaling function (ON, OFF)
- Steps per turn (1 ... 8192)
- Total resolution (GA) -- 1 ... 67,108,864 steps, with $GA = 2^n \times SpU$. -- ($n=0 \dots 13$)
- "Activation of SSA-service" ²⁾
- Selection of the station address ²⁾

Configuration

Setting the formats (IN/OUT) for the cyclic data interchange via configuration byte (K-1)

2 words IN/OUT data (I-1/O-1) ¹⁾

4 words IN/OUT data (I-1, I-2, I-3/O-1) ²⁾

Data interchange: - Input Data (IN)

I-1	Position value ¹⁾	4 bytes
I-2	Speed (rev/min) ²⁾	2 bytes
I-3	Time stamp ²⁾	2 bytes

Data interchange: - Output data (OUT)

O-1	PRESET Value ¹⁾	4 bytes
-----	----------------------------	---------

Diagnostic information

- Station-related diagnosis (63 bytes in acc. with Encoder Profile Class 2)

Setting: - PRESET value

The PRESET function is used for set into operation and to allocate a specific position value to the current physical angular position.

The following settings are possible:

- by hardware (PRESET push button: S3)
- by software: -- (see Output data)

Setting: - Counting direction

- by hardware via DIP switch S1-(8)
- by software via Telegram

Counting direction increasing:

Rotation of the shaft in the clockwise direction (CW) as viewed on the shaft

Setting: - Station address

- by hardware via DIP switch S1
- by software via Telegram

The setting by software is carried out only if the "SSA-service" has been previously activated.

Setting: - Bus termination

The 2-way DIP switch (S2) permits an internal bus termination to be switched in and out (ON/OFF).

If the bus is terminated externally, switch S2 must be in the OFF position.

Device-specific file (GS.)

For the purpose of automatic set into operation of the encoder, use is made of the GS file.

All the characteristic features of the device are defined in it.

STEG 00FE.GSD German
STEG 00FE.GSE English
STEG 00FE.GSF French

¹⁾ As per Encoder Profile

²⁾ Manufacturer specific function



Resolution up to 26 bits

Absolute Encoder Multiturn

- Extremely robust
- RS 485 bus coupling to Profibus DP Specification
- Electronically adjustable, resolution adjustable
- Highly shock- and vibration-proof
- High degree of protection IP 65

Dimensional drawing through hollow shaft, connector radial

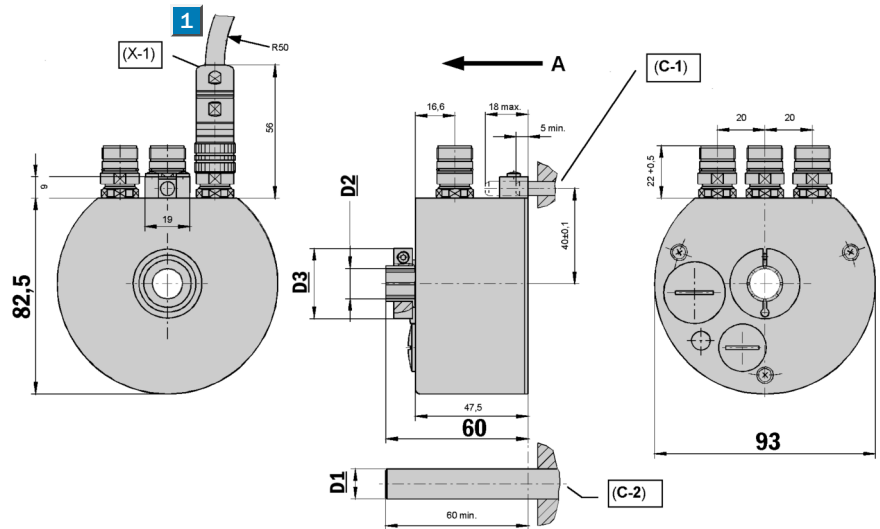

Through hollow shaft	D1	D2	D3
12 mm	12.0 _{h7}	12.0 ^{F7}	29.5
1/2"	12.7 _{h7}	12.7 ^{F7}	29.5
16 mm	16.0 _{h7}	16.0 ^{F7}	32.0

C - 1	Torque support via cylindrical pin (customer) Ø 6 _{m6} to DIN EN ISO 8734
C - 2	Drive shaft (customer)
X - 1	7 pin plug connector MINITEC, (3x)
A	Direction of view on encoder (used to define the direction of rotation)

PIN and wire allocation Profibus DP (In/Out)

PIN	Signal	Explanation
1	RTS	Request To Send ²⁾
2	A	Profibus DP A line
3	N. C.	Not connected
4	B	Profibus DP B line
5	2M	0 V (potential free) ¹⁾
6	2P5	+ 5 V (potential free) ¹⁾
7	N. C.	Not connected

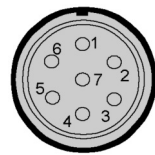

¹⁾ Use for external bus termination or to supply the transmitter/receiver of an optical fibre transmission link.

²⁾ Signal is optional, is used to detect the direction of an optical fibre connection.

PIN and wire allocation U_s

PIN	Signal	Explanation
1	U _s (24 V)	Supply voltage
2	N. C.	Not connected
3	GND (0 V)	0 V (Gnd)
4	N. C.	Not connected
5	RTS	Request To Send ²⁾
6	N. C.	Not connected
7	N. C.	Not connected

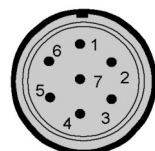

²⁾ Signal is optional, is used to detect the direction of an optical fibre connection.
N. C. = Not connected



Accessories

Connection systems

Technical data acc. to DIN 32878		ATM90 Profibus connector radial		Flange type	
				through	
Hollow shaft diameter	12, 16 mm, 1/2"				
Mass	Approx. 0.6 kg				
Moment of inertia of the rotor	153 gcm ²				
Measuring step	0.043°				
Max. number of steps per revolution	8,192				
Max. number of revolutions	8,192				
Error limits	± 0.25°				
Repeatability	0.1°				
Operating speed	3,000 min ⁻¹				
Position forming time	0.25 ms				
Max. angular acceleration	0.6 x 10 ⁵ rad/s ²				
Operating torque	0.4 Ncm				
Start up torque	0.5 Ncm				
Bearing lifetime	3.6 x 10 ⁹ revolutions				
Working temperature range	- 20 ... + 80 °C				
Storage temperature range	- 40 ... + 125 °C				
Permissible relative humidity	98 %				
EMC ¹⁾					
Resistance					
to shocks ²⁾	100/6 g/ms				
to vibration ³⁾	20/10 ... 2000 g/Hz				
Protection class acc. IEC 60529					
with shaft seal	IP 65				
Operating voltage range (Us)	10 ... 32 V				
Power consumption	2.0 W				
Initialisation time ⁴⁾	1250 ms				
Bus Interface Profibus DP					
Electrical Interface ⁵⁾	RS 485				
Protocol	Profile for Encoders (07 _{hex}) – Class 2				
Address setting (node number)	0 ... 127 (DIP switches or protocol)				
Data transmission rate (baud rate)	9.6 kBaud - 12 MBaud				
	automatic detection				
Electronic adjustment (number SET)	Via PRESET push button or protocol				
Status information	Operation (green LED), bus activity (red LED)				
Bus termination ⁶⁾	Via DIP switches				
Electrical connection	M14 plug connector (7 pin)				

¹⁾ To DIN EN 61000-6-2 and DIN EN 61000-6-3

²⁾ To DIN EN 60068-2-27

³⁾ To DIN EN 60068-2-6

⁴⁾ From the moment the supply voltage is applied, this is the time which elapses before the data word can be correctly read in

⁵⁾ To EN 50 170-2 (DIN 19245 part 1-3) DC isolated via opto-couplers

⁶⁾ Should only be connected in the final device

Order information		
ATM90 Profibus through hollow shaft; connector radial; U _s 10 ... 32 V		
Type	Part no.	Explanation
ATM90-PTF13X13	1 030 042	Through hollow Ø 12 mm, 3 x M14, 8.192 x 8.192
ATM90-PUF13X13	1 030 043	Through hollow Ø 1/2", 3 x M14, 8.192 x 8.192
ATM90-PXF13X13	1 030 044	Through hollow Ø 16 mm, 3 x M14, 8.192 x 8.192
ATM90-PTF13X11	1 032 654	Through hollow Ø 12 mm, 3 x M14, 8.192 x 2.048
ATM90-PUF13X11	1 032 655	Through hollow Ø 1/2", 3 x M14, 8.192 x 2.048
ATM90-PXF13X11	1 032 656	Through hollow Ø 16 mm, 3 x M14, 8.192 x 2.048
ATM90-PTF12X12	1 032 660	Through hollow Ø 12 mm, 3 x M14, 4.096 x 4.096
ATM90-PUF12X12	1 032 661	Through hollow Ø 1/2", 3 x M14, 4.096 x 4.096
ATM90-PXF12X12	1 032 662	Through hollow Ø 16 mm, 3 x M14, 4.096 x 4.096
ATM90-PTF11X13	1 032 896	Through hollow Ø 12 mm, 3 x M14, 2.048 x 8.192
ATM90-PUF11X13	1 032 897	Through hollow Ø 1/2", 3 x M14, 2.048 x 8.192
ATM90-PXF11X13	1 032 898	Through hollow Ø 16 mm, 3 x M14, 2.048 x 8.192



Resolution up to 26 bits

Absolute Encoder Multiturn

- Extremely robust
- RS 485 bus coupling to Profibus DP Specification
- Electronically adjustable, resolution adjustable
- Highly shock- and vibration-proof
- High degree of protection IP 65

Dimensional drawing through hollow shaft cable radial

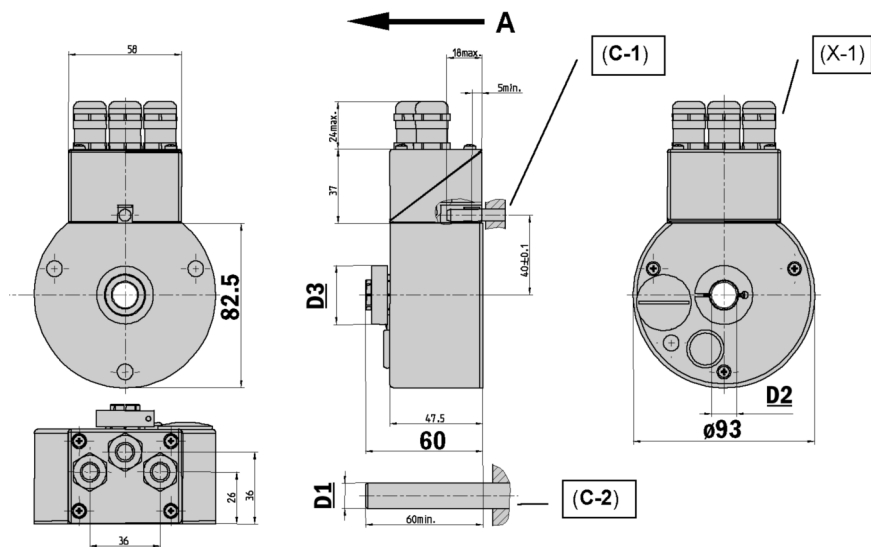

General tolerances according DIN ISO 2768-mk

Through hollow shaft	D1	D2	D3
12 mm	12.0 _{h7}	12.0 ^{F7}	29.5
1/2"	12.7 _{h7}	12.7 ^{F7}	29.5
16 mm	16.0 _{h7}	16.0 ^{F7}	32.0

C - 1	Torque support via cylindrical pin (customer) $\varnothing 6_{m6}$ to DIN EN ISO 8734
C - 2	Drive shaft (customer)
X - 1	3x screw fixings for cable connection, metric M16 x 1.5, 17
A	Direction of view on encoder (used to define the direction of rotation)

PIN and wire allocation for Profibus adaptor

PIN	Signal	Explanation
1	U _s (24 V)	Supply voltage
2	GND (0 V)	0 V (Gnd)
3	B	Profibus DP B line (out)
4	A	Profibus DP A line (out)
5	B	Profibus DP B line (in)
6	A	Profibus DP A line (in)
7	2P5	+ 5 V (potential free) ¹⁾
8	2M	0 V (potential free) ¹⁾
9	RTS	Request To Send ²⁾

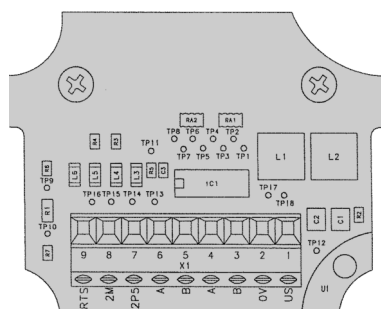

¹⁾ Use for external bus termination or to supply the transmitter/receiver of an optical transmission link.

²⁾ Signal is optional, used to detect the direction of an optical connection.

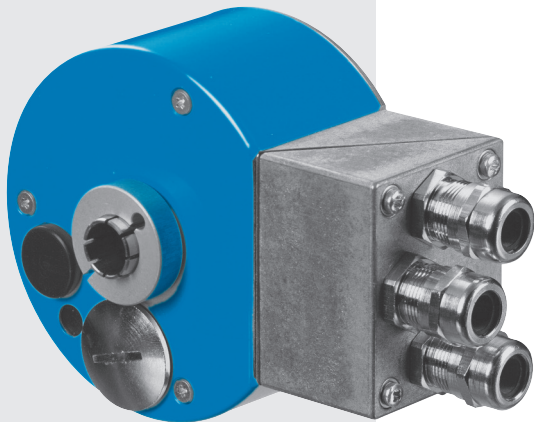

Technical data acc. to DIN 32878		ATM90 Profibus with bus adaptor		Flange type	
				through	
Hollow shaft diameter	12, 16 mm, 1/2"				
Mass	Approx. 0.8 kg				
Moment of inertia of the rotor	153 gcm ²				
Measuring step	0.043°				
Max. number of steps per revolution	8,192				
Max. number of revolutions	8,192				
Error limits	± 0.25°				
Repeatability	0.1°				
Operating speed	3,000 min ⁻¹				
Position forming time	0.25 ms				
Max. angular acceleration	0.6 x 10 ⁵ rad/s ²				
Operating torque	0.4 Ncm				
Start up torque	0.5 Ncm				
Bearing lifetime	3.6 x 10 ⁹ revolutions				
Working temperature range	- 20 ... + 80 °C				
Storage temperature range	- 40 ... + 125 °C				
Permissible relative humidity	98 %				
EMC ¹⁾					
Resistance					
to shocks ²⁾	100/6 g/ms				
to vibration ³⁾	20/10 ... 2000 g/Hz				
Protection class acc. IEC 60529					
with shaft seal	IP 65				
Operating voltage range (Us)	10 ... 32 V				
Power consumption	2.0 W				
Initialisation time ⁴⁾	1250 ms				
Bus Interface Profibus DP					
Electrical Interface ⁵⁾	RS 485				
Protocol	Profile for Encoders (07 _{hex}) – Class 2				
Address setting (node number)	DIP switches or protocol				
Data transmission rate (baud rate)	9.6 kBaud - 12 MBaud				
	Automatic detection				
Electronic adjustment (number SET)	Via PRESET push button or protocol				
Status information	Operation (green LED), bus activity (red LED)				
Bus termination ⁶⁾	Via DIP switches				
Electrical connection	Screw fixing for cable (3x)				

¹⁾ To DIN EN 61000-6-2 and DIN EN 61000-6-3

²⁾ To DIN EN 60068-2-27

³⁾ To DIN EN 60068-2-6

⁴⁾ From the moment the supply voltage is applied, this is the time which elapses before the data word can be correctly read in

⁵⁾ To EN 50 170-2 (DIN 19245 part 1-3) DC isolated via opto-couplers

⁶⁾ Should only be connected in the final device

Order information		
ATM90 Profibus through hollow shaft; cable radial; U _s 10 ... 32 V		
Type	Part no.	Explanation
ATM90-PTG13X13	1 030 045	Through hollow Ø 12 mm, 3 x PG, 8.192 x 8.192
ATM90-PUG13X13	1 030 046	Through hollow Ø 1/2", 3 x PG, 8.192 x 8.192
ATM90-PXG13X13	1 030 047	Through hollow Ø 16 mm, 3 x PG, 8.192 x 8.192
ATM90-PTG13X11	1 032 657	Through hollow Ø 12 mm, 3 x PG, 8.192 x 2.048
ATM90-PUG13X11	1 032 658	Through hollow Ø 1/2", 3 x PG, 8.192 x 2.048
ATM90-PXG13X11	1 032 659	Through hollow Ø 16 mm, 3 x PG, 8.192 x 2.048
ATM90-PTG12X12	1 032 663	Through hollow Ø 12 mm, 3 x PG, 4.096 x 4.096
ATM90-PUG12X12	1 032 664	Through hollow Ø 1/2", 3 x PG, 4.096 x 4.096
ATM90-PXG12x12	1 032 665	Through hollow Ø 16 mm, 3 x PG, 4.096 x 4.096
ATM90-PTG11x13	1 032 899	Through hollow Ø 12 mm, 3 x PG, 2.048 x 8.192
ATM90-PUG11x13	1 032 900	Through hollow Ø 1/2", 3 x PG, 2.048 x 8.192
ATM90-PXG11x13	1 032 901	Through hollow Ø 16 mm, 3 x PG, 2.048 x 8.192
Attention: Bus adaptor included		



Resolution up to 26 bits

Absolute Encoder Multiturn

- Extremely robust
- RS 485 bus coupling to Profibus DP Specification
- Electronically adjustable, resolution adjustable
- Highly shock- and vibration-proof
- High degree of protection IP 65

Switch settings

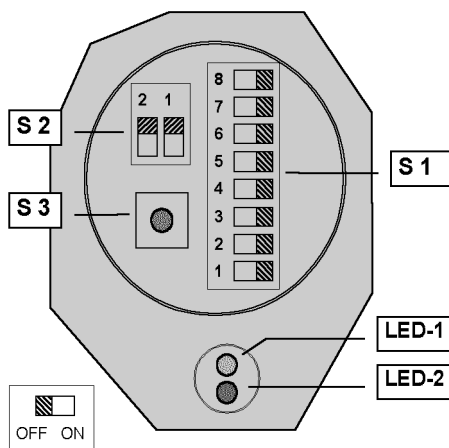

Switch settings

Access to the DIP switches used for configuring the encoder can be gained by removing the screw on the back of the encoder.

- S 1 (1-7) Address setting (0 ... 127)
- S 1 (8-8) Counting direction (CW/CCW)
- S 2 Bus termination
- S 3 Preset push button (Number SET)

In the version with a cable connection, the switches S1 and S2 are located inside the bus adaptor.

Status information via LEDs

- LED-1 Operating voltage (green)
- LED-2 Bus activity (red)



Accessories

Connection systems

Implementation

DP Functionalities

in accordance with the Profibus DP basic functions.

DP services

- Data interchange (Write_Read_Data)
- Address allocation (Set_Slave_Address)
- Control commands (Global_Control)
- Read the inputs (Read_Inputs)
- Read the outputs (Read_Outputs)
- Read diagnostic data (Slave_Diagnosis)
- Send configuration data (Set_Param)
- Check configuration data (Chk_Config)

Communication

- Cyclic master – slave data traffic

Protective mechanisms

- Data transfer with HD = 4
- Time monitoring of the data traffic

Configuration

Settings in accordance with Encoder Profile

- Counting direction (CW, CCW)
- Class 2 functionality (ON, OFF)
- Scaling function (ON, OFF)
- Steps per turn (1 ... 8,192)
- Total resolution (TR) -- 1...6,108,864 steps, with $TR = 2^n \times CPR$ -- ($n=0 \dots 13$)
- "Activation of SSA-service" ²⁾
- Selection of the station address ²⁾

Configuration

Setting the data format (Cx) for the cyclic data interchange (In/Out) via configuration byte (K-1).

C1 ¹⁾ 2 Word (IO) (I-1/O-1)

C2 ²⁾ 4 Word (IO) (I-1, I-2, I-3/O-1)

Data interchange: - Input Data (IN)

I-1	Position value ¹⁾	4 bytes
I-2	Speed (rev/min) ²⁾	2 bytes
I-3	Time stamp ²⁾	2 bytes

Data interchange: - Output data (OUT)

O-1 PRESET Value ¹⁾ 4 bytes

Diagnostic information

- Station-related diagnosis (63 bytes in acc. with Encoder Profile Class 2)

Setting: - PRESET value

The PRESET function is used for set into operation and to allocate a specific position value to the current physical angular position.

The following settings are possible:

- by hardware (PRESET push button: S3)
- by software: -- (see Output data)

Setting: - Counting direction

- by hardware via DIP switch S1-(8)
- by software via Telegram

Counting direction increasing:

Rotation of the shaft in the clockwise direction (CW) as viewed on the shaft.

Setting: - Station address

- by hardware via DIP switch S1
- by software via Telegram

The setting by software is carried out only if the "SSA-service" has been previously activated.

Setting: - Bus termination

The 2-way DIP switch (S2) permits an internal bus termination to be switched in and out (ON/OFF).

If the bus is terminated externally, switch S2 must be in the OFF position.

Device-specific file (GS.)

For the purpose of automatic set into operation of the encoder, use is made of the GS file.

All the characteristic features of the device are defined in it.

STEG 00FE.GSD	German
STEG 00FE.GSE	English
STEG 00FE.GSF	French

¹⁾ As per Encoder Profile

²⁾ Manufacturer specific function



Resolution up to 26 bits

Absolute Encoder Multiturn

- Extremely robust
- Bus coupling to CAN-High speed specification
- Electronically adjustable, resolution adjustable
- Highly shock- and vibration-proof
- High degree of protection IP 67

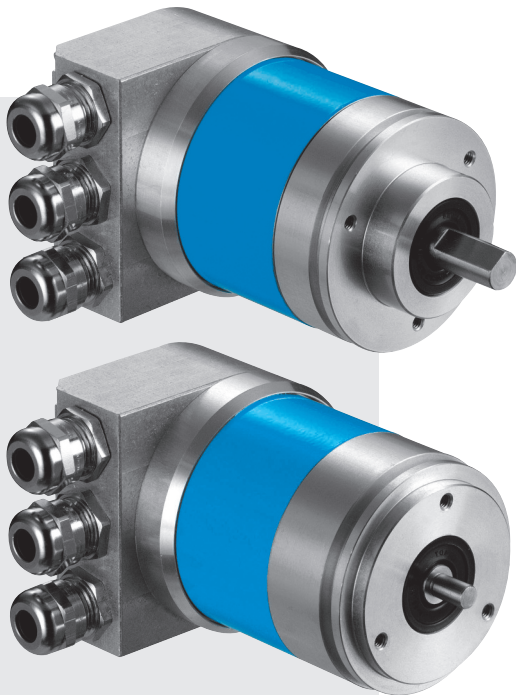

Dimensional drawing face mount flange

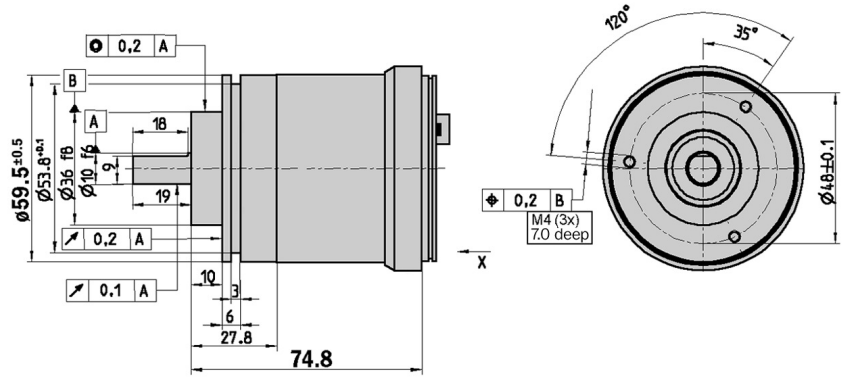

General tolerances according DIN ISO 2768-mk

Dimensional drawing servo flange

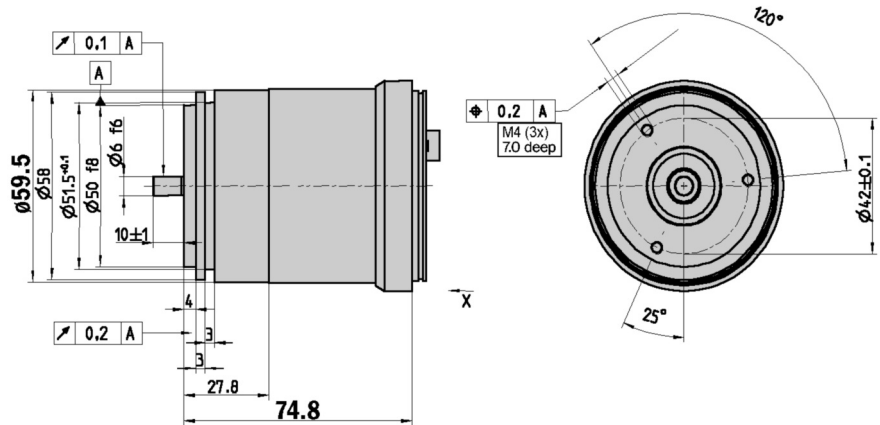

General tolerances according DIN ISO 2768-mk



1 Encoders with a CANbus adaptor have a terminal strip for connecting the bus and supply lines. In order to connect the lines, the Profibus adaptor is unscrewed from the complete device. The figure 1 shows the pin allocation within the bus connection.

Accessories

- Bus adaptor
- Mounting systems

1 PIN and wire allocation for bus adaptor

Terminal strip	Connector	Signal	Explanation
1	1	Shield	Screen
2	2	U_s (24 V)	Supply voltage 10 ... 32 V
3	3	GND (COM)	0V (Gnd)
4	4	CAN _H	CAN Bus Signal HIGH
5	5	CAN _L	CAN Bus Signal LOW
6		CAN _H	CAN Bus Signal HIGH
7		CAN _L	CAN Bus Signal LOW
8		GND (COM)	0V (Gnd)
9		U_s (24 V)	Supply voltage 10 ... 32 V

Figure 1

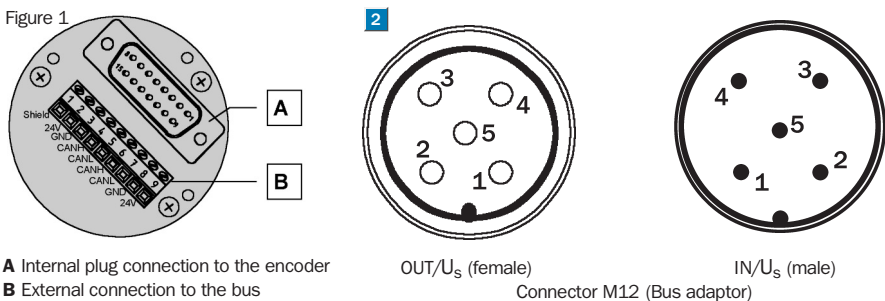

Technical data according to DIN 32878		ATM60 CANopen		Flange type									
		face m.	servo										
Solid shaft	10 mm												
	6 mm												
Mass	Approx. 0.59 kg												
Moment of inertia of the rotor	35 gcm ²												
Measuring step	0.043°												
Max. number of steps per revolution	8,192												
Max. number of revolutions	8,192												
Error limits	± 0.25°												
Repeatability	0.1°												
Operating speed	6,000 min ⁻¹												
Position forming time	0.25 ms												
Max. angular acceleration	5 x 10 ⁵ rad/s ²												
Operating torque													
with shaft seal	1.8 Ncm												
without shaft seal ¹⁾	0.3 Ncm												
Start up torque													
with shaft seal	2.5 Ncm												
without shaft seal ²⁾	0.5 Ncm												
Max. shaft loading													
radial	300 N												
axial	50 N												
Bearing lifetime	3.6 x 10 ⁹ revolutions												
Working temperature range	- 20 ... + 80 °C												
Storage temperature range	- 40 ... + 125 °C												
Permissible relative humidity	98 %												
EMC ²⁾													
Resistance													
to shocks ³⁾	100/6 g/ms												
to vibration ⁴⁾	20/10 ... 2000 g/Hz												
Protection class acc. IEC 60529													
with shaft seal	IP 67												
without shaft seal ⁵⁾	IP 43												
without shaft seal ⁶⁾	IP 66												
Operating voltage range (Us)	10 ... 32 V												
Power consumption	2.0 W												
Initialisation time ⁷⁾	1250 ms												
Bus Interface CANopen													
Electrical interface ⁸⁾	ISO-DIS 11898												
Protocol	Communication Profile DS 301 V4.0												
	Device Profile DSP 406 V2.0												
Address setting (NODE ID)	0 ... 63 (DIP switches or protocol)												
Data transmission rate (Baudrate)	{10, 20, 50, 125, 250, 500} kB, 1MB (DIP switches or protocol)												
Electronic adjustment (number SET)	Via PRESET push button or protocol												
Status Information	2-colour LED for CAN Controller status												
Bus termination ⁹⁾	Via DIP switches												
Electrical connection	Screw fixing with PG-9 for cable												

¹⁾ In case that shaft seal has been removed by customer

²⁾ To DIN EN 61000-6-2 and DIN EN 61000-6-3

³⁾ To DIN EN 60068-2-27

⁴⁾ To DIN EN 60068-2-6

⁵⁾ Not sealed at encoder flange

⁶⁾ Sealed at encoder flange

⁷⁾ From the moment the supply voltage is applied, this is the time which elapses before the data word can be correctly read in

⁸⁾ (CAN High Speed) and CAN Specification 2.0 B, DC isolated

⁹⁾ Should only be connected in the final device

Order information

ATM60 CANopen face mount and servo flange; solid shaft; U_s 10 ... 32 V

Type	Part no.	Explanation
ATM60-C4H13X13	1 030 024	Face mount solid shaft Ø 10 mm
ATM60-C1H13X13	1 030 025	Servo flange solid shaft Ø 6 mm

Attention: Please order the CANbus adaptor separately (see page 26)



Resolution up to 26 bits

Absolute Encoder Multiturn

- Extremely robust
- Bus coupling to CAN-High speed specification
- Electronically adjustable, resolution adjustable
- Highly shock- and vibration-proof
- High degree of protection IP 67

Dimensional drawing blind hollow shaft

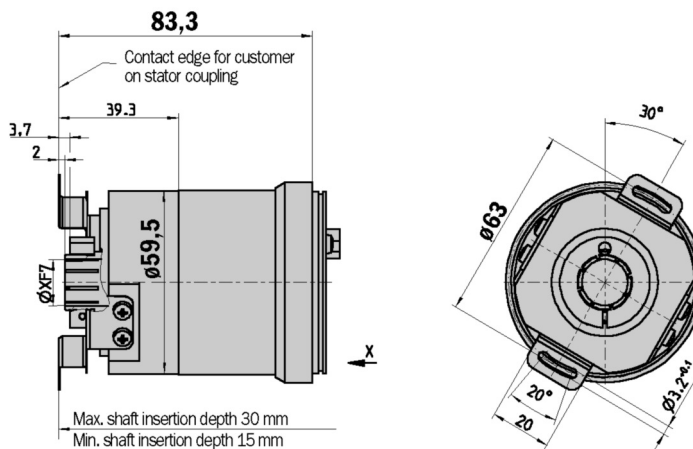

General tolerances according DIN ISO 2768-mk

1 PIN and wire allocation for bus adaptor

Terminal strip	Connector	Signal	Explanation
1	1	Shield	Screen
2	2	U _s (24 V)	Supply voltage 10 ... 32 V
3	3	GND (COM)	0V (Gnd)
4	4	CAN _H	CAN Bus Signal HIGH
5	5	CAN _L	CAN Bus Signal LOW
6		CAN _H	CAN Bus Signal HIGH
7		CAN _L	CAN Bus Signal LOW
8		GND (COM)	0V (Gnd)
9		U _s (24 V)	Supply voltage 10 ... 32 V

Figure 1

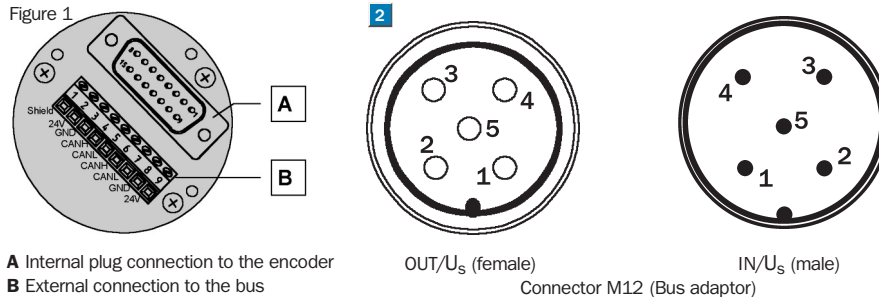

A Internal plug connection to the encoder
B External connection to the bus

OUT/U_s (female)
 IN/U_s (male)
 Connector M12 (Bus adaptor)

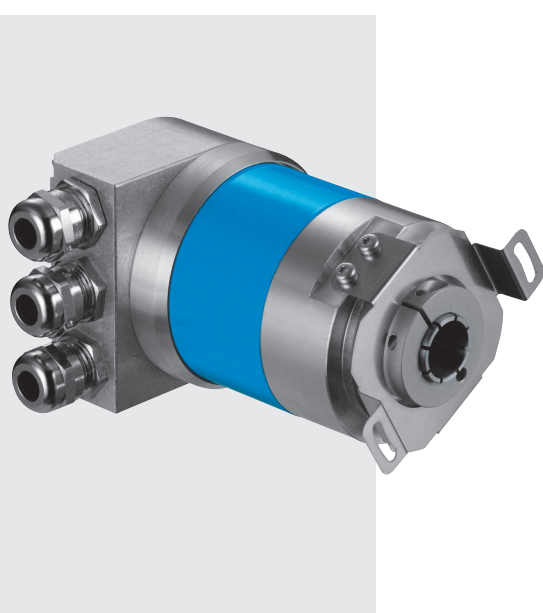

1 Encoders with a CANbus adaptor have a terminal strip for connecting the bus and supply lines. In order to connect the lines, the Profibus adaptor is unscrewed from the complete device. The figure 1 shows the pin allocation within the bus connection.

Accessories

- Bus adaptor
- Collets

Technical data according to DIN 32878		ATM60 CANopen								Flange type								
										blind								
1 Hollow shaft diameter	6, 8, 10, 12, 15 mm, 1/4", 3/8", 1/2"																	
Mass	Approx. 0.59 kg																	
Moment of inertia of the rotor	55 gcm ²																	
Measuring step	0.043°																	
Max. number of steps per revolution	8,192																	
Max. number of revolutions	8,192																	
Error limits	± 0.25°																	
Repeatability	0.1°																	
Operating speed	3,000 min ⁻¹																	
Position forming time	0.25 ms																	
Max. angular acceleration	5 x 10 ⁵ rad/s ²																	
Operating torque	0.8 Ncm ¹⁾																	
Start up torque	1.2 Ncm ¹⁾																	
Permissible shaft movement of the drive element																		
radial static/dynamic	± 0.3/± 0.1 mm																	
axial static/dynamic	± 0.5/± 0.2 mm																	
Bearing lifetime	3.6 x 10 ⁹ revolutions																	
Working temperature range	- 20 ... + 80 °C																	
Storage temperature range	- 40 ... + 125 °C																	
Permissible relative humidity	98 %																	
EMC ²⁾																		
Resistance																		
to shocks ³⁾	100/6 g/ms																	
to vibration ⁴⁾	20/10 ... 2000 g/Hz																	
Protection class acc. IEC 60529 ¹⁾	IP 67																	
without shaft seal ⁵⁾	IP 43																	
Operating voltage range (Us)	10 ... 32 V																	
Power consumption	2.0 W																	
Initialisation time ⁶⁾	1250 ms																	
Bus Interface CANopen																		
Electrical interface ⁷⁾	ISO-DIS 11898																	
Protocol	Communication Profile DS 301 V4.0 Device Profile DSP 406 V2.0																	
Address setting (NODE ID)	0 ... 63 (DIP switches or protocol)																	
Data transmission rate (Baudrate)	{10, 20, 50, 125, 250, 500} kB, 1MB (DIP switches or protocol)																	
Electronic adjustment (number SET)	Via PRESET push button or protocol																	
Status Information	2-colour LED for CAN Controller status																	
Bus termination ⁸⁾	Via DIP switches																	
Electrical connection	Screw fixing with PG-9 for cable																	

¹⁾ With shaft seal

²⁾ To DIN EN 61000-6-2 and DIN EN 61000-6-3

³⁾ To DIN EN 60068-2-27

⁴⁾ To DIN EN 60068-2-6

⁵⁾ Not sealed at encoder flange

⁶⁾ From the moment the supply voltage is applied, this is the time which elapses before the data word can be correctly read in.

⁷⁾ (CAN High Speed) and CAN Specification 2.0 B, DC isolated

⁸⁾ Should only be connected in the final device

Order information

ATM60 CANopen blind hollow shaft; U_s 10 ... 32 V

Type	Part no.	Explanation
ATM60-CAH13X13	1 030 026	Blind hollow shaft

Attention: Please order the CANbus adaptor separately (see page 26)

1 Attention: Please order the collet with required diameter separately

Type	Part no.	Shaft diameter
SPZ-006-AD-A	2 029 174	6 mm
SPZ-1E4-AD-A	2 029 175	1/4"
SPZ-008-AD-A	2 029 176	8 mm
SPZ-3E8-AD-A	2 029 177	3/8"
SPZ-010-AD-A	2 029 178	10 mm
SPZ-012-AD-A	2 029 179	12 mm
SPZ-1E2-AD-A	2 029 180	1/2"
SPZ-014-AD-A	2 048 863	14 mm

For 15 mm shaft diameter, collet is not needed



Resolution up to 26 bits

Absolute Encoder Multiturn

- Extremely robust
- Bus coupling to CAN-High speed specification
- Electronically adjustable, resolution adjustable
- Highly shock- and vibration-proof
- High degree of protection IP 67

Dimensional drawing CANopen adaptor KR1

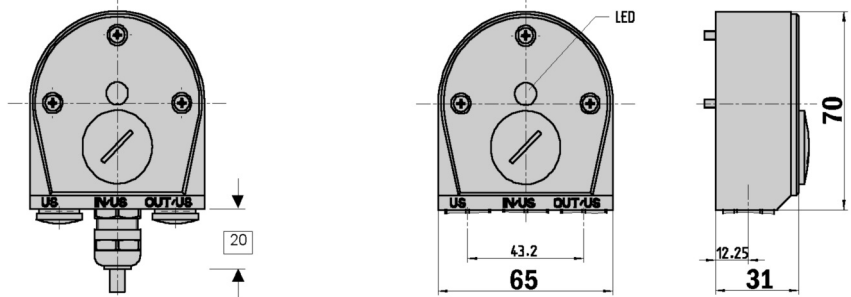

General tolerances according DIN ISO 2768-mk

Dimensional drawing CANopen adaptor KR2

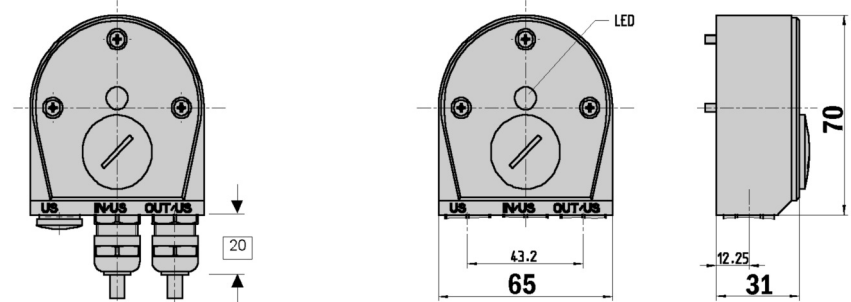

General tolerances according DIN ISO 2768-mk

Dimensional drawing CANopen adaptor KR3

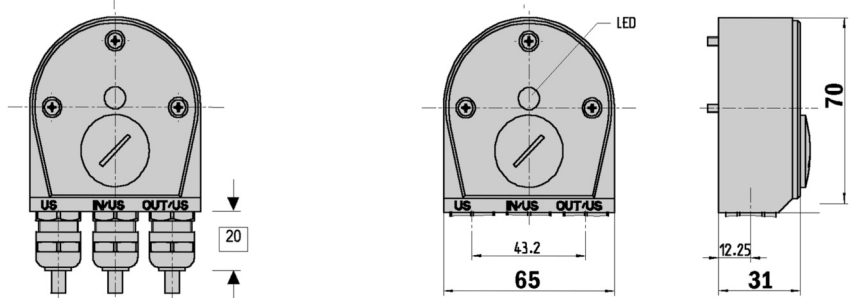

General tolerances according DIN ISO 2768-mk

Dimensional drawing CANopen adaptor SR2

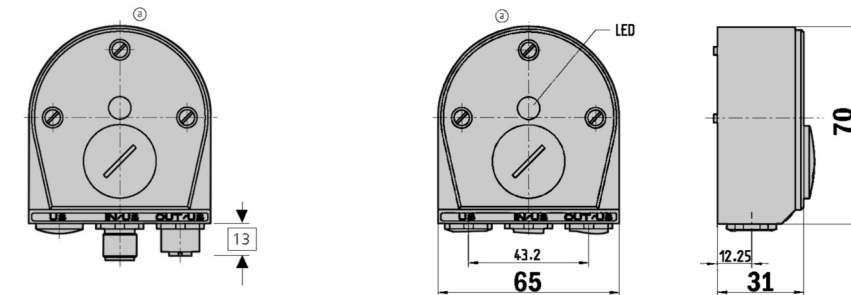

General tolerances according DIN ISO 2768-mk

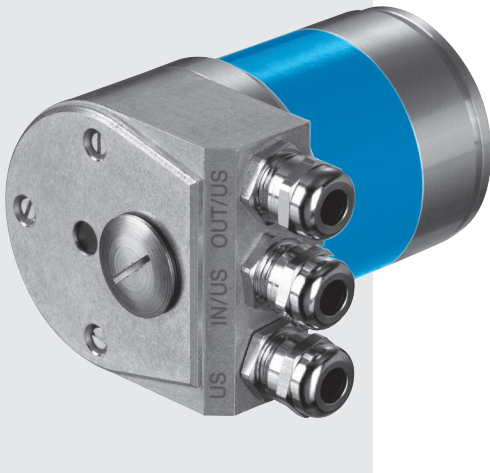

Order information

ATM60 CANopen adaptor

Type	Part no.	Explanation
AD-ATM60-KR1C0	2 029 230	Bus adaptor KR1, 1 x PG
AD-ATM60-KR2C0	2 029 231	Bus adaptor KR2, 2 x PG
AD-ATM60-KR3C0	2 029 232	Bus adaptor KR3, 3 x PG
AD-ATM60-SR2C0	2 020 935	Bus adaptor SR2, 2 x M12, 5 pin.
AD-ATM60-SR1C0	2 031 686	Bus adaptor SR1, 1 x M12, 5 pin.

Switch settings

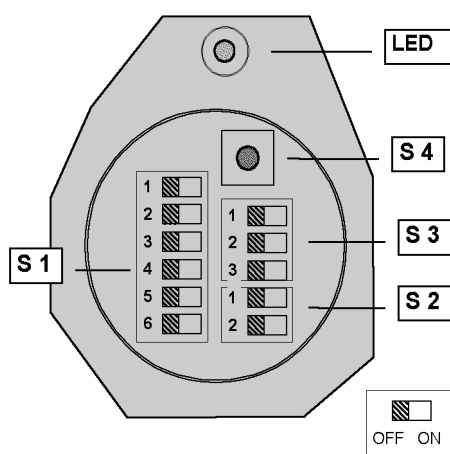
Switch settings

Access to the switches is gained by opening the removable screw cap (PG) on the rear of the bus adaptor. Use of the following elements.

S 1	Address setting (Node ID)
S 2	Bus termination
S 3	Baud rate setting (Data Rate)
S 4	Preset push button (Number zero SET)

Status information via LED

LED	2-colour red/green
	CAN Controller status

Implementation

CANopen Functionality

Predefined Connection Set

- Sync Object
- Emergency Object
- NMT Network Object (Error Control services, Boot-Up service)
- One Service Data Object (SDO)
- Two Process Data Object (PDO)

I/O-Operating Modes

- Synchronous: -- Depends on Sync Object
- Asynchronous. -- No reference to Sync Object. Triggered by "Timer" (Cyclic) or by event (COS)
- Remote Transmission (RTR)

Encoder Parameters

according the Device Profile for Encoders:

- Code direction (CW, CCW)
- Scaling function (ON, OFF)
- PRESET value
- Steps per revolution (CPR) - 1 ... 8,192
- Total resolution (TR) -- 1 ... 67,108,864 steps, with $TR = 2^n \times CPR$ -- ($n=0 \dots 13$)
- Limits for the working range
- Cycle Timer for asynchronous PDOs
- 8 programmable cams with HIGH/LOW limits and hysteresis
- General Diagnostic parameters (Offset Value, Alarms, Warnings, version of profile and software)

Manufacturer specific Profile:

- Node commissioning. -- Location and values for Node-ID and Baud rate
- Hysteresis to position change required for Async PDOs with COS mode
- Limits and display format for the speed and acceleration values

PDO Data Mapping

Mapping of up to four data objects to each of the two Transmit PDOs. The resulting data length within one PDO is limited to 8 Byte.

(1) Object 1/Pos Val ¹⁾	I-1
(n) Object 2 ... Object 4	I-1 to I-7

Input Data Objects

I-1 Position value [Pos Val]	4 Byte
I-2 Status of cam	1 Byte
I-3 Status of working range	1 Byte
I-4 Alarms	1 Byte
I-5 Warnings	1 Byte
I-6 Speed value	4 Byte
I-7 Acceleration value	4 Byte

Setting: - Address (Node ID)

0 to 63 by Hardware (DIP Switch) or EEPROM

Setting: - Baud rate

10kb, 20kb, 50kb, 125kb, 250kb, 500kb, 1 MB by Hardware (DIP Switch) or EEPROM

Setting: - Bus Termination

The DIP-Switch (S2) is used to switch on/off an internal bus termination (ON/OFF). Not used (OFF) in case of using an external termination of the network

Setting: - PRESET Value

The Preset function supports adaptation of the encoder zero point to the mechanical zero point of the encoder system. The factory PRESET value is zero [0]

The adjustment is carried out in 2 ways:

- by Hardware (PRESET push button)
- by Software (CANopen Protocol)

Equipment Configuration

Configuring parameters of the encoder can be achieved by a configuration tool in conjunction with an EDS file (Electronic Data Sheet). It contains all the characteristics of the encoder.

¹⁾ Default Setting

 **Resolution up to 26 bits**
Absolut Encoder Multiturn

- Extremely robust
- Bus coupling to CAN-High speed specification
- Electronically adjustable, resolution adjustable
- Highly shock- and vibration-proof
- High degree of protection IP 67

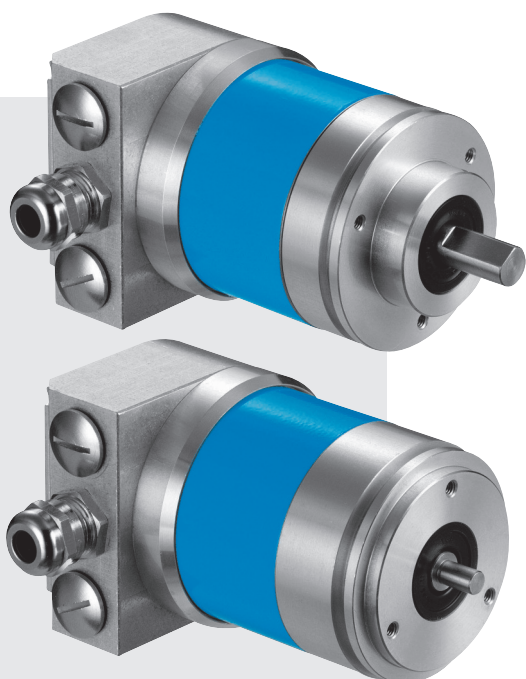

Dimensional drawing face mount flange

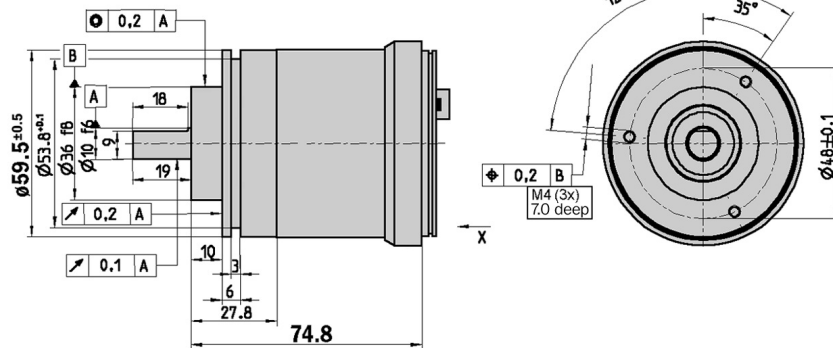

General tolerances according DIN ISO 2768-mk

Dimensional drawing servo flange

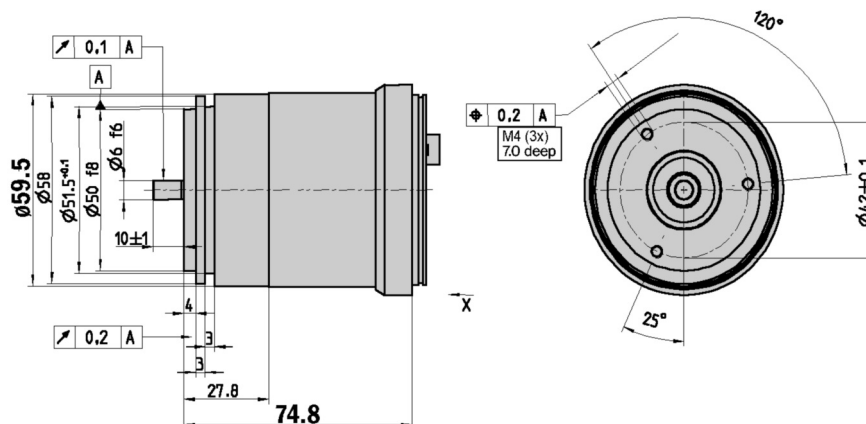

General tolerances according DIN ISO 2768-mk



1 Encoders with a DeviceNet adaptor have a terminal strip for connecting the bus and supply lines. In order to connect the lines, the DeviceNet adaptor is unscrewed from the complete device. The figure 1 shows the pin allocation within the bus connection.

Accessories
Bus adaptor
Mounting systems

1 PIN and wire allocation for bus adaptor

Terminal strip	Connector	Signal	Explanation
1	1	Shield	Screen
2	2	U _S (24 V)	Supply voltage 10 ... 32 V
3	3	GND (COM)	0V (Gnd)
4	4	CAN _H	CAN Bus Signal HIGH
5	5	CAN _L	CAN Bus Signal LOW
6		CAN _H	CAN Bus Signal HIGH
7		CAN _L	CAN Bus Signal LOW
8		GND (COM)	0V (Gnd)
9		U _S (24 V)	Supply voltage 10 ... 32 V

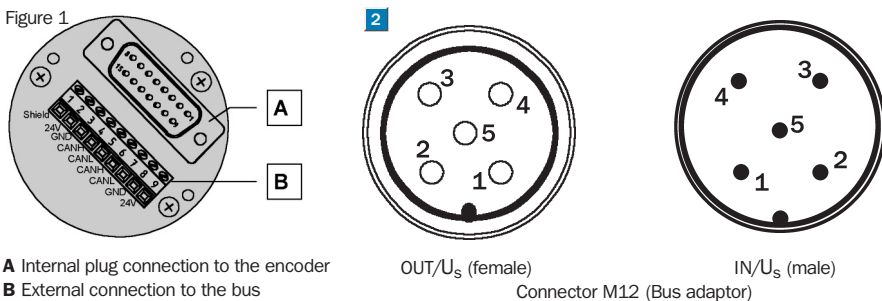

Technical data according to DIN 32878		ATM60 DeviceNet		Flange type							
		face m.	servo								
Solid shaft	10 mm										
	6 mm										
Mass	Approx. 0.59 kg										
Moment of inertia of the rotor	35 gcm ²										
Measuring step	0.043°										
Max. number of steps per revolution	8,192										
Max. number of revolutions	8,192										
Error limits	± 0.25°										
Repeatability	0.1°										
Operating speed	6,000 min ⁻¹										
Position forming time	0.25 ms										
Max. angular acceleration	5 x 10 ⁵ rad/s ²										
Operating torque	1.8 Ncm ¹⁾										
without shaft seal ¹⁾	0.3 Ncm										
Start up torque	2.5 Ncm ¹⁾										
without shaft seal ²⁾	0.5 Ncm										
Max. shaft loading											
radial	300 N										
axial	50 N										
Bearing lifetime	3.6 x 10 ⁹ revolutions										
Working temperature range	- 20 ... + 80 °C										
Storage temperature range	- 40 ... + 125 °C										
Permissible relative humidity	98 %										
EMC ³⁾											
Resistance											
to shocks ⁴⁾	100/6 g/ms										
to vibration ⁵⁾	20/10 ... 2000 g/Hz										
Protection class acc. IEC 60529											
with shaft seal	IP 67										
without shaft seal ⁶⁾	IP 43										
without shaft seal ⁷⁾	IP 66										
Operating voltage range (Us)	10 ... 32 V										
Power consumption	2.0 W										
Initialisation time ⁸⁾	1250 ms										
Bus Interface DeviceNet											
Electrical interface ⁹⁾	ISO-DIS 11898										
Protocol	DeviceNet Specification, Release 2.0										
Address setting (NODE ID)	0 ... 63 (DIP switches or protocol)										
Data transmission rate (Data Rate)	{125, 250, 500} kB (DIP switches or protocol)										
Electronic adjustment (Number SET)	Via PRESET push button or protocol										
Status Information	Network Status LED (NS), 2-colours										
Bus Termination ¹⁰⁾	Via DIP switches										
Electrical Connection	Bus adaptor ¹¹⁾										

¹⁾ With shaft seal
²⁾ In case that shaft seal has been removed by customer
³⁾ To DIN EN 61000-6-2 and DIN EN 61000-6-3
⁴⁾ To DIN EN 60068-2-27
⁵⁾ To DIN IEN 60068-2-6
⁶⁾ Not sealed at encoder flange
⁷⁾ Sealed at encoder flange
⁸⁾ From the moment the supply voltage is applied, this is the time which elapses before the data word can be correctly read in.
⁹⁾ (CAN High Speed) and CAN Specification 2.0 B, DC isolated
¹⁰⁾ Should only be connected in the final device
¹¹⁾ For cable with PG 9 or connector (see bus adaptor)

Order information		
ATM60 DeviceNet face mount and servo flange solid shaft; U _s 10 ... 32 V		
Type	Part no.	Explanation
ATM60-D4H13X13	1 030 017	Face mount solid shaft Ø 10 mm
ATM60-D1H13X13	1 030 018	Servo flange solid shaft Ø 6 mm
Attention: Please order the DeviceNet adaptor separately (see page 32)		



Resolution up to 26 bits

Absolute Encoder Multiturn

- Extremely robust
- Bus coupling to CAN-High speed specification
- Electronically adjustable, resolution adjustable
- Highly shock- and vibration-proof
- High degree of protection IP 67

Dimensional drawing blind hollow shaft

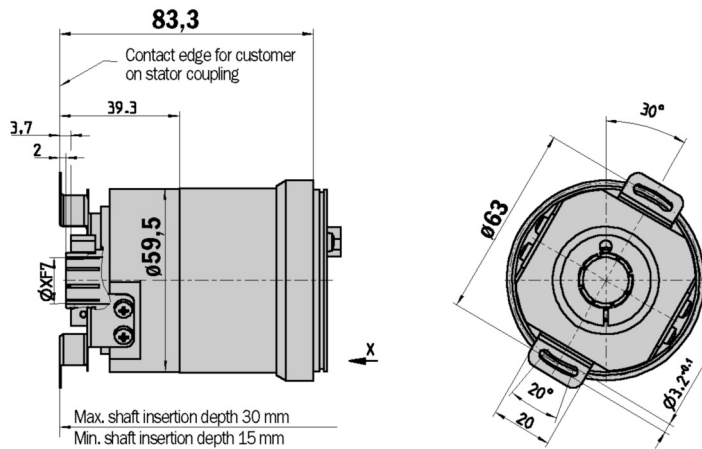

General tolerances according DIN ISO 2768-mk

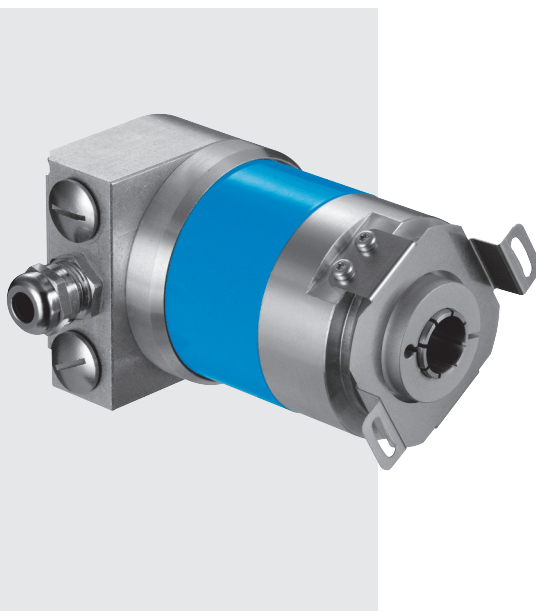

1 PIN and wire allocation for bus adaptor

Terminal strip	Connector	Signal	Explanation
1	1	Shield	Screen
2	2	U_s (24 V)	Supply voltage 10 ... 32 V
3	3	GND (COM)	0V (Gnd)
4	4	CAN _H	CAN Bus Signal HIGH
5	5	CAN _L	CAN Bus Signal LOW
6		CAN _H	CAN Bus Signal HIGH
7		CAN _L	CAN Bus Signal LOW
8		GND (COM)	0V (Gnd)
9		U_s (24 V)	Supply voltage 10 ... 32 V

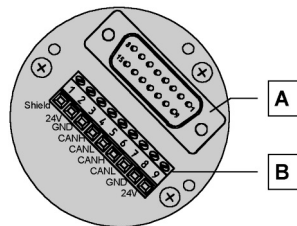

1 Encoders with a DeviceNet adaptor have a terminal strip for connecting the bus and supply lines. In order to connect the lines, the DeviceNet adaptor is unscrewed from the complete device. The figure shows the pin allocation within the bus connection.

A Internal plug connection to the encoder
B External connection to the bus



Accessories

- Bus adaptor
- Collets

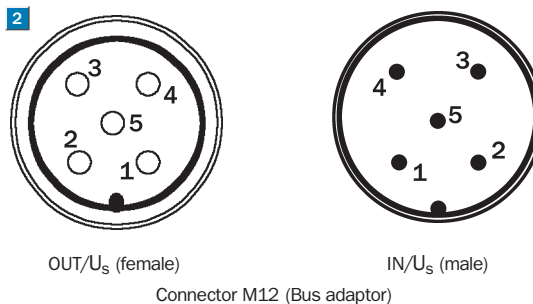

Technical data according to DIN 32878		ATM60 DeviceNet		Flange type					
				blind					
1 Hollow shaft diameter	6, 8, 10, 12, 15 mm, 1/4", 3/8", 1/2"								
Mass	Approx. 0.59 kg								
Moment of inertia of the rotor	55 gcm ²								
Measuring step	0.043°								
Max. number of steps per revolution	8,192								
Max. number of revolutions	8,192								
Error limits	± 0,25°								
Repeatability	0.1°								
Operating speed	3,000 min ⁻¹								
Position forming time	0.25 ms								
Max. angular acceleration	5 x 10 ⁵ rad/s ²								
Operating torque	0.8 Ncm ¹⁾								
Start up torque	1.2 Ncm ¹⁾								
Permissible shaft movement of the drive element									
radial static/dynamic	± 0.3/± 0.1 mm								
axial static/dynamic	± 0.5/± 0.2 mm								
Bearing lifetime	3.6 x 10 ⁹ revolutions								
Working temperature range	- 20 ... + 80 °C								
Storage temperature range	- 40 ... + 125 °C								
Permissible relative humidity	98 %								
EMC ²⁾									
Resistance									
to shocks ³⁾	100/6 g/ms								
to vibration ⁴⁾	20 /10 ... 2000 g/Hz								
Protection class acc. IEC 60529 ¹⁾	IP 67								
without shaft seal ⁵⁾	IP 43								
Operating voltage range (Us)	10 ... 32 V								
Power consumption	2.0 W								
Initialisation time ⁶⁾	1250 ms								
Bus Interface DeviceNet									
Electrical interface ⁷⁾	ISO-DIS 11898								
Protocol	DeviceNet Specification, Release 2.0								
Address setting (NODE ID)	0 ... 63 (DIP switches or protocol)								
Data transmission rate (Data Rate)	{125, 250, 500} kB (DIP switches or protocol)								
Electronic adjustment (Number SET)	Via PRESET push button or protocol								
Status Information	Network Status LED (NS), 2-colours								
Bus Termination ⁸⁾	Via DIP switches								
Electrical Connection	Bus adaptor ⁹⁾								

¹⁾ With shaft seal

²⁾ To DIN EN 61000-6-2 and DIN EN 61000-6-3

³⁾ To DIN EN 60068-2-27

⁴⁾ To DIN EN 60068-2-6

⁵⁾ Not sealed at encoder flange

⁶⁾ From the moment the supply voltage is applied, this is the time which elapses before the data word can be correctly read in

⁷⁾ (CAN High Speed) and CAN Specification 2.0 B, DC isolated

⁸⁾ Should only be connected in the final device

⁹⁾ For cable with PG 9 or connector (see bus adaptor)

Order information

ATM60 DeviceNet blind hollow shaft; U_s 10 ... 32 V

Type	Part no.	Explanation
ATM60-DAH13X13	1 030 019	Blind hollow shaft

Attention: Please order the DeviceNet adaptor separately (see page 32)

1 Attention: Please order the collet with required diameter separately

Type	Part no.	Shaft diameter
SPZ-006-AD-A	2 029 174	6 mm
SPZ-1E4-AD-A	2 029 175	1/4"
SPZ-008-AD-A	2 029 176	8 mm
SPZ-3E8-AD-A	2 029 177	3/8"
SPZ-010-AD-A	2 029 178	10 mm
SPZ-012-AD-A	2 029 179	12 mm
SPZ-1E2-AD-A	2 029 180	1/2"
SPZ-014-AD-A	2 048 863	14 mm

For 15 mm shaft diameter, collet is not needed



Resolution up to 26 bits

Absolute Encoder Multiturn

- Extremely robust
- Bus coupling to CAN-High speed specification
- Electronically adjustable, resolution adjustable
- Highly shock- and vibration-proof
- High degree of protection IP 67

Dimensional drawing DeviceNet adaptor SR1

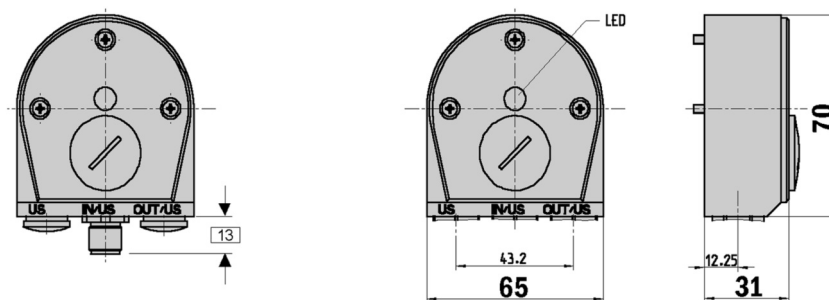

General tolerances according DIN ISO 2768-mk

Dimensional drawing DeviceNet adaptor SR2

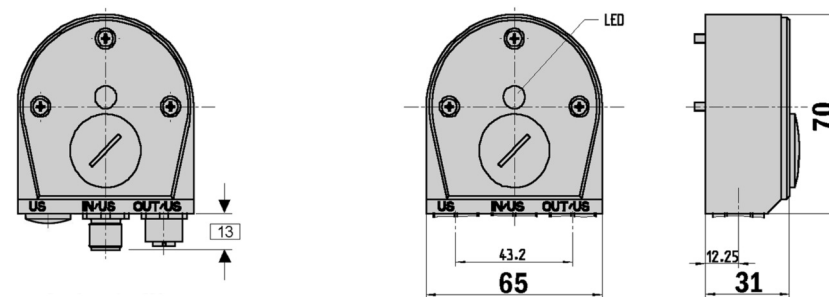

General tolerances according DIN ISO 2768-mk

Dimensional drawing DeviceNet adaptor KR1

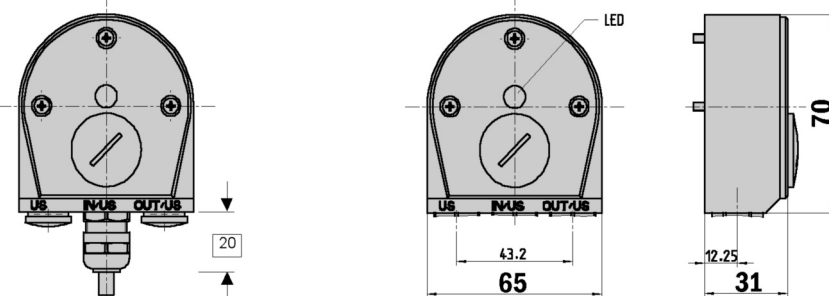

General tolerances according DIN ISO 2768-mk

Dimensional drawing DeviceNet adaptor KR2

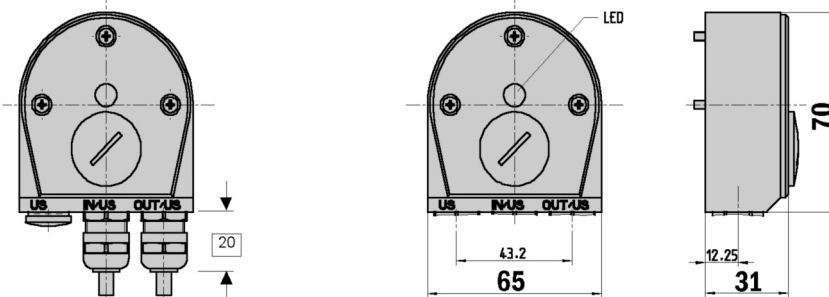

General tolerances according DIN ISO 2768-mk

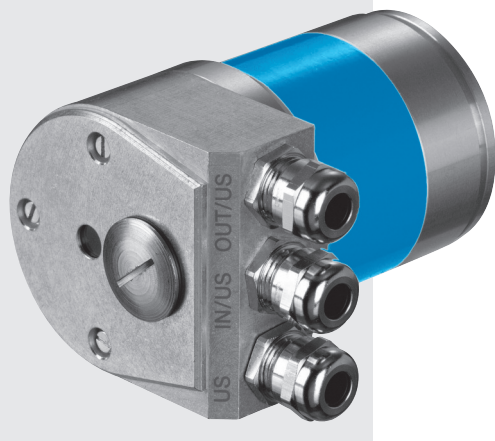

Accessories

Connection systems

Order information

ATM60 DeviceNet adaptor

Type	Part no.	Explanation
AD-ATM60-SR1DN	2 029 226	Bus adaptor SR1, 1 x M12, 5 pin
AD-ATM60-SR2DN	2 029 227	Bus adaptor SR2, 2 x M12, 5 pin
AD-ATM60-KR1DN	2 029 228	Bus adaptor KR1, 1 x PG
AD-ATM60-KR2DN	2 029 229	Bus adaptor KR2, 2 x PG

Switch settings

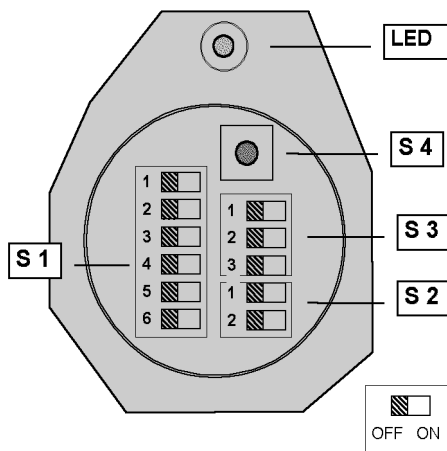

Switch settings

Access to the switches is gained by opening the removable screw cap (PG) on the rear of the bus adaptor. Use of the following elements.

- S 1 Address setting (Node ID)
- S 2 Bus termination
- S 3 Baud rate setting (Data Rate)
- S 4 Preset push button (Number zero SET)

Status information (NS) via LED

- LED 2-colour red/green
- Network communication status

Implementation

DN Functionality

Object model

- Identity Object
- Message Router Object
- DeviceNet Object
- Assembly Object
- Connection Object
- Acknowledge Handler Object
- Encoder Object

I/O-Operating Modes

- Polling
- Change of State/Cyclic
- Bits Strobe

Encoder Parameters

according to the Device Profile for Encoders:

- Code direction (CW, CCW)
- Scaling function (ON, OFF)
- PRESET value
- Hysteresis to position change of required for COS communication
- Steps per revolution (CPR) - 1 ... 8,192
- Total resolution (TR) -- 1 ... 67,108,864 steps, with TR = 2ⁿ x CPR -- (n=0 ... 13)
- Limits for the working range (software limit switches)
- Limits and display format for the speed and acceleration values
- 8 programmable cams with HIGH/LOW limits and hysteresis
- General Diagnostic parameters (Offset Value, Alarms, Warnings, version of profile and software)

Manufacturer specific parameters:

- Assignment of the I/O Data Assembly to the different I/O operating modes
- Diagnostic data indicating the current maximum results of the encoder
- Device-specific data

I/O Data Assembly

- 1) Pos Val (Position Value) ¹⁾ I-1
- 2) Pos Val + Flag I-1, I-2
- 3) Pos Val + Speed I-1, I-3
- 4) Pos Val + Status of Cam I-1, I-4

Input Data Objects

- I-1 Position value [Pos Val] 4 Byte
- I-2 Flag (Alarm, Warning) 1 Byte
- I-3 Speed 4 Byte
- I-4 Status of cam 1 Byte

Setting: - Address (Node ID)

0 to 63 by Hardware (DIP Switch)

Setting: - Baud rate

125kb, 250kb, 500kb by Hardware (DIP Switch)

Setting: - Bus Termination

The DIP Switch (S2) is used to switch on/off an internal bus termination (ON/OFF). Not used (OFF) in case of using an external termination of the network

Setting: - PRESET Value

The Preset function supports adaptation of the encoder zero point to the mechanical zero point of the encoder system. The factory PRESET value is zero [0]

The adjustment is carried out in 2 ways:

- by Hardware (PRESET push button)
- by Software (DeviceNet Protocol)

Equipment Configuration

Configuring parameters of the encoder can be achieved by a configuration tool in conjunction with an EDS file (Electronic Data Sheet). It contains all the characteristics of the encoder.

¹⁾ Default Setting

Dimensional drawings and order information

Programming tool for SSI interface

Programming tool for ATM60/ATM90

Type	Part no.
PGT-01-S	1 030 111

Screw-in system M23, 12 pin for ATM60/ATM90 with SSI interface

Connector M23 female, 12 pin, straight, screened

Type	Part no.	Contacts
D0S-2312-G	6 027 538	12

Connector M23 male, 12 pin, straight, screened

Type	Part no.	Contacts
STE-2312-G	6 027 537	12

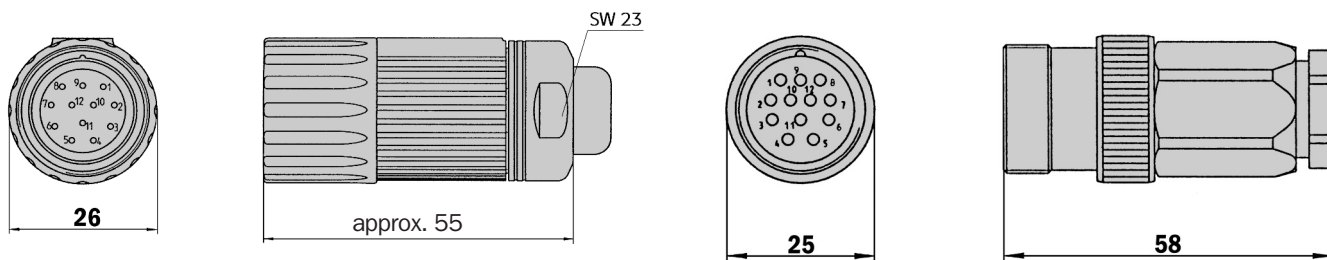

General tolerances according to DIN ISO 2768-mk

General tolerances according to DIN ISO 2768-mk

Connector M23 female, 12 pin, straight, cable 12 cores, 4 x 2 x 0.25 + 2 x 0.5 + 2 x 0.14 mm² screened, capable of being dragged, cable diameter 7.8 mm for ATM60/ATM90 with SSI interface

Type	Part no.	Contacts	Cable length
DOL-2312-G1M5MA1	2 029 200	12	1.5 m
DOL-2312-G03MMA1	2 029 201	12	3.0 m
DOL-2312-G05MMA1	2 029 202	12	5.0 m
DOL-2312-G10MMA1	2 029 203	12	10.0 m
DOL-2312-G20MMA1	2 029 204	12	20.0 m
DOL-2312-G30MMA1	2 029 205	12	30.0 m

Cable 12 core, per meter, 4 x 2 x 0.25 + 2 x 0.5 + 2 x 0.14 mm² screened, capable of being dragged, cable diameter 7.8 mm for ATM60/ATM90 with SSI interface

Type	Part no.	Wires	Explanation
LTG-2512-MW	6 027 531	12	
LTG-2612-MW	6 028 516	12	UV- and salt water resistant

Adaptor modules for SSI interface

Serial Parallel Adaptors

Type	Part no.	Explanation
AD-SSIG-PA	1 030 106	SSI Parallel Adaptor module, in plastic housing
AD-SSI-PA	1 030 107	SSI Parallel Adaptor module, without plastic housing
AD-SSIPG-PA	1 030 108	SSI Parallel Adaptor module, programmable, in plastic housing
AD-SSIPF-PA	1 030 109	SSI Parallel Adaptor module, programmable, without plastic housing, with front plate
AD-SSIP-PA	1 030 110	SSI Parallel Adaptor module, programmierbar, without plastic housing, without front plate

Programming tool for Serial Parallel Adaptor

Type	Part no.
PGT-02-S	1 030 112

Dimensional drawings and order information

Screw-in system Sub-D for Serial Parallel adaptor

Cable connector Sub-D male, 15 pin, straight, screened

Type	Part no.	Contacts
STE-0D15-G	2 029 223	15

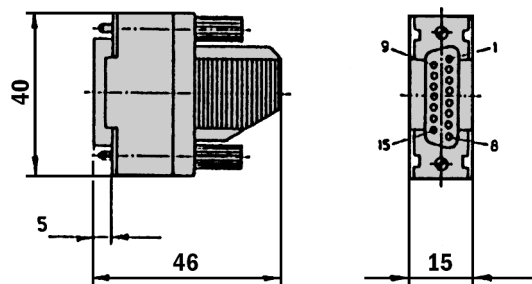

General tolerances according to DIN ISO 2768-mk

Cable connector Sub-D female, 37 pin, straight, screened

Type	Part no.	Contacts
DOS-0D37-G	2 029 224	37

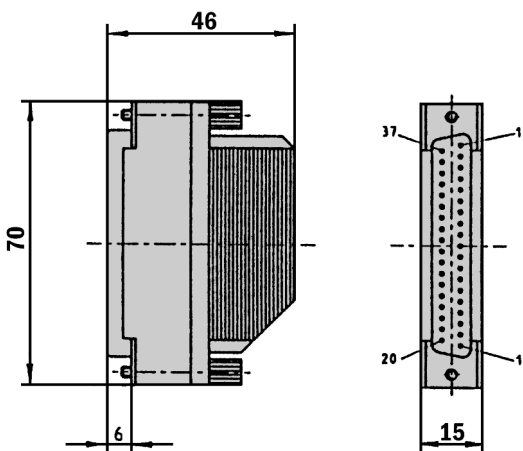

General tolerances according to DIN ISO 2768-mk

Screw-in system M12, 5 pin for ATM60 DeviceNet

Cable connector M12 female, 5 pin, straight, screened

Type	Part no.	Contacts
DOS-1205-G	6 027 534	5

Cable connector M12 male, 5 pin, straight, screened

Type	Part no.	Contacts
STE-1205-G	6 027 533	5

SENSICK Profibus connector for ATM60/ATM90

Type	Part no.	Explanation
PR-DOS-1205-G	6 021 353	Profibus-female connector, M12, 5 pin, straight, shielded, B-coding
PR-STE-1205-G	6 021 354	Profibus- male connector, M12, 5 pin, straight, shielded, B-coding
DOL-12PR-G05M	6 026 006	Profibus-female connector, M12, 5 pin, straight, shielded, B-coding, with Profibus cable 5 m
DOL-12PR-G10M	6 026 007	Profibus-female connector, M12, 5 pin, straight, shielded, B-coding, with Profibus cable 10 m
STL-12PR-G05M	6 026 005	Profibus-male connector, M12, 5 pin, straight, shielded, B-coding, with Profibus cable 5 m
STL-12PR-G10M	6 026 008	Profibus-male connector, M12, 5 pin, straight, shielded, B-coding, with Profibus cable 10 m

SENSICK round connector M12 terminal screwed for operating voltage ATM60 Profibus

Type	Part no.	Contacts	Explanation
DOS-1204-G	6 007 302	4	Female connector, M12, 4 pin, straight

SENSICK round connector M12, PVC cable

Type	Part no.	Explanation
DOL-1204-G05M	6 009 866	Female connector, M12, 4 pin, straight, cable 5 m

Signal cable (Profibus specification) by the metre, shielded for ATM60/ATM90 Profibus

Type	Part no.	Wires
LTG-2102-MW	6 021 355	2

Screw-in system M14 for ATM90 Profibus

Type	Part no.	Explanation
DSC-1507-G	2 029 199	Cable connector male/female, Set 2 x male, 1 x female, M14, 7 pin, straight (screened)
STE-1507-G	6 027 535	Cable connector, M14 male, 7 pin, straight (screened)
DOS-1507-G	6 027 536	Cable connector, M14 female, 7 pin, straight (screened)

Dimensional drawings and order information

Couplings

Bellows coupling, max. shaft offset radial ± 0.3 mm, axial 0.4 mm, angle ± 4 degrees, torsion spring stiffness 120 Nm/rad, bellows of stainless steel, hubs of aluminium

Type	Part no.	Shaft diameter
KUP-0606-B	5 312 981	6 mm ... 6 mm
KUP-0610-B	5 312 982	6 mm ... 10 mm
KUP-1010-B	5 312 983	10 mm ... 10 mm
KUP-1012-B	5 312 984	10 mm ... 12 mm

Cheese-head screw
M2,5x8 DIN912 A2

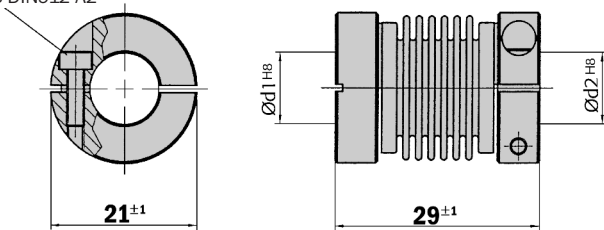

Spring-disc coupling, max. shaft offset radial ± 0.3 mm, axial 0.4 mm, angle ± 2.5 degrees, torsion spring stiffness 50 Nm/rad, flange of aluminium, spring-discs of glass-fibre-reinforced plastic

Type	Part no.	Shaft diameter
KUP-0610-F	5 312 985	6 mm ... 10 mm
KUP-1010-F	5 312 986	10 mm ... 10 mm

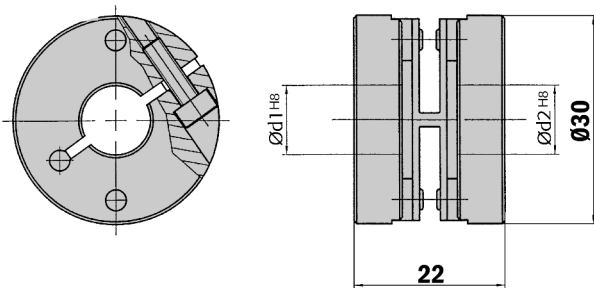

General tolerances according DIN ISO 2768-mk

Dimensional drawings and order information

Mechanical Adaptors

Adaptor flange of aluminium for face mount flanges, spigot 36 mm

Type	Part no.	Adaption
BEF-FA-036-050	2 029 160	To 50 mm servo flange

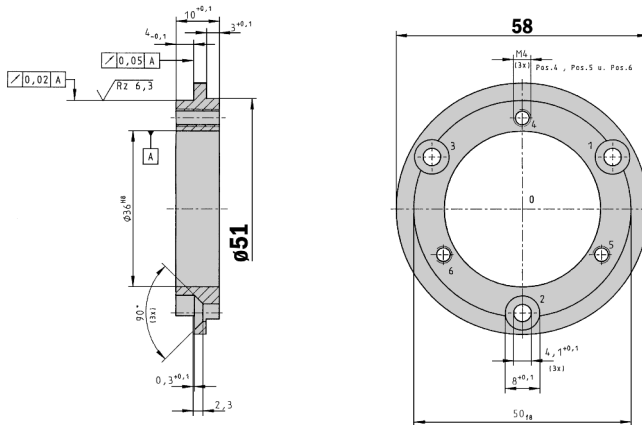

General tolerances according DIN ISO 2768-mk

Adaptor flange of aluminium for face mount flanges, spigot 36 mm

Type	Part no.	Adaption
BEF-FA-036-100	2 029 161	To 100 mm servo flange

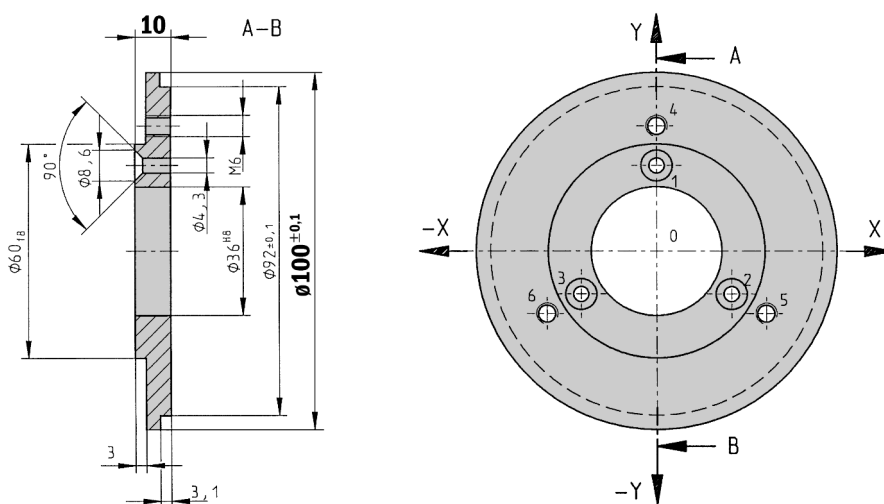

General tolerances according DIN ISO 2768-mk

Dimensional drawings and order information

Mechanical Adaptors

Adaptor flange of aluminium for face mount flanges, spigot 36 mm

Type	Part no.	Adaption
BEF-FA-036-060REC	2 029 162	To 60 mm square mounting plate

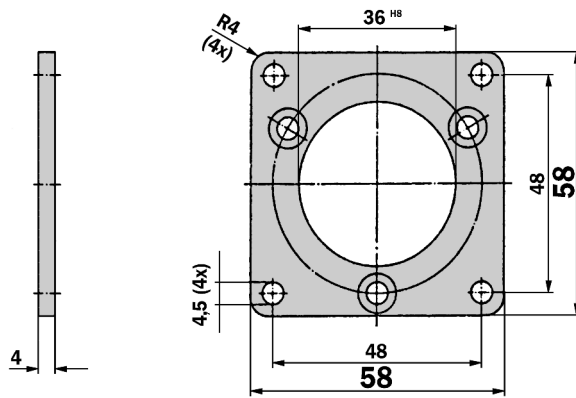

General tolerances according DIN ISO 2768-mk

Adaptor flange of aluminium for face mount flanges, spigot 36 mm

Type	Part no.	Adaption
BEF-FA-036-060RSA	2 029 163	To 60 mm square mounting plate with shock absorbers

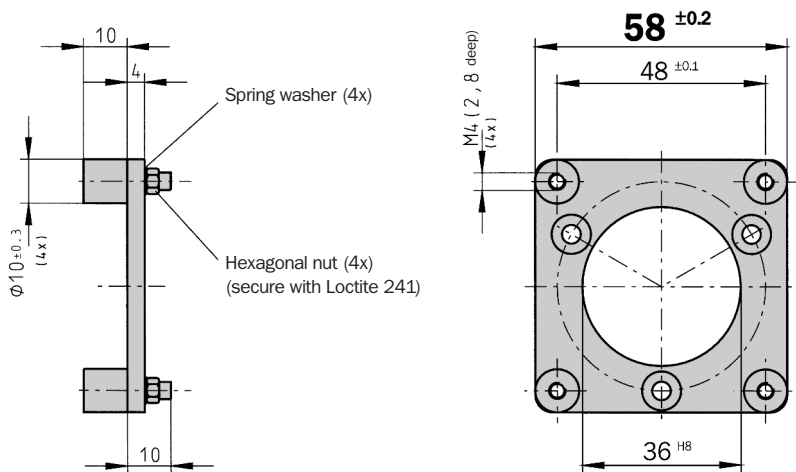

General tolerances according DIN ISO 2768-mk

Dimensional drawings and order information

Mounting bell incl. fixing set for encoder with servo flange

Type	Part no.	Flange spigot
BEF-MG-50	5 312 987	Diameter 50 mm

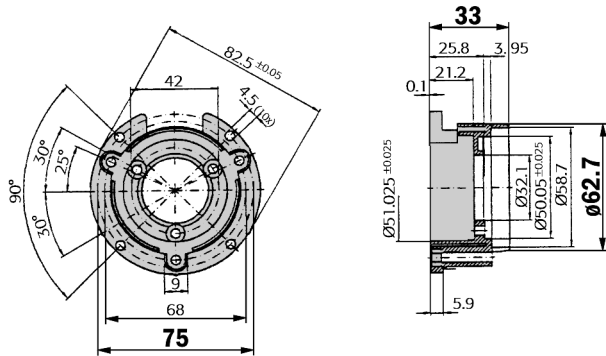

General tolerances according DIN ISO 2768-mk

Mounting angle incl. fixing set for encoder with face mount flange

Type	Part no.	Flange spigot
BEF-WF-36	2 029 164	Diameter 36 mm

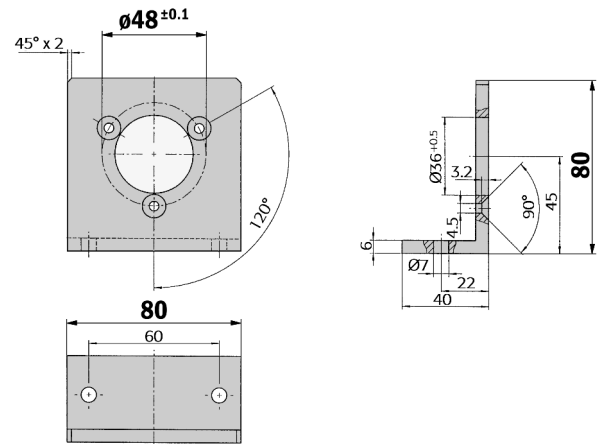

General tolerances according DIN ISO 2768-mk

Servo clamps half ring, Set (comprises 2 pieces) for servo flanges with spigot diameter 50 mm

Type	Part no.
BEF-WG-SF050	2 029 165

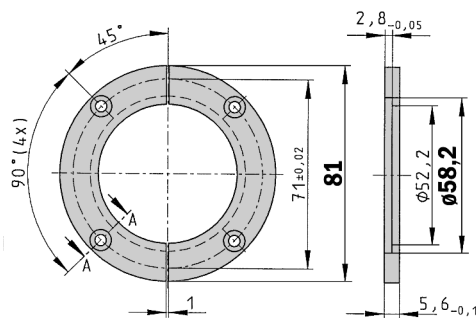

General tolerances according DIN ISO 2768-mk

Servo clamps small, Set (comprises 3 pieces) for servo flanges

Type	Part no.
BEF-WK-SF	2 029 166

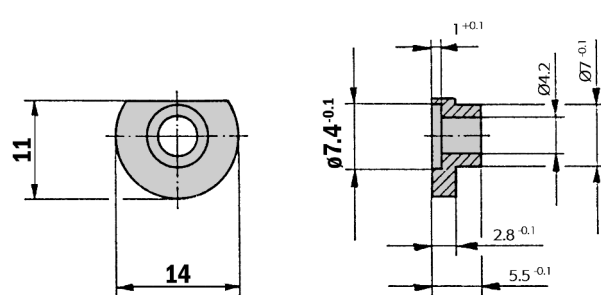

General tolerances according DIN ISO 2768-mk

Collets

Collets for blind hollow shaft

Type	Part no.	Shaft diameter
SPZ-006-AD-A	2 029 174	6 mm
SPZ-1E4-AD-A	2 029 175	1/4"
SPZ-008-AD-A	2 029 176	8 mm
SPZ-3E8-AD-A	2 029 177	3/8"
SPZ-010-AD-A	2 029 178	10 mm
SPZ-012-AD-A	2 029 179	12 mm
SPZ-1E2-AD-A	2 029 180	1/2"
SPZ-014-AD-A	2 048 863	14 mm

Australia

Phone +61 3 9497 4100
1800 33 48 02 – tollfree
E-Mail sales@sick.com.au

Belgium/Luxembourg

Phone +32 (0)2 466 55 66
E-Mail info@sick.be

Brasil

Phone +55 11 3215-4900
E-Mail sac@sick.com.br

Ceská Republika

Phone +420 2 57 91 18 50
E-Mail sick@sick.cz

China

Phone +852-2763 6966
E-Mail ghk@sick.com.hk

Danmark

Phone +45 45 82 64 00
E-Mail sick@sick.dk

Deutschland

Phone +49 211 5301-250
E-Mail info@sick.de

España

Phone +34 93 480 31 00
E-Mail info@sick.es

France

Phone +33 1 64 62 35 00
E-Mail info@sick.fr

Great Britain

Phone +44 (0)1727 831121
E-Mail info@sick.co.uk

India

Phone +91-22-4033 8333
E-Mail info@sick-india.com

Israel

Phone +972-4-999-0590
E-Mail info@sick-sensors.com

Italia

Phone +39 02 27 43 41
E-Mail info@sick.it

Japan

Phone +81 (0)3 3358 1341
E-Mail support@sick.jp

Nederlands

Phone +31 (0)30 229 25 44
E-Mail info@sick.nl

Norge

Phone +47 67 81 50 00
E-Mail austefjord@sick.no

Österreich

Phone +43 (0)22 36 62 28 8-0
E-Mail office@sick.at

Polska

Phone +48 22 837 40 50
E-Mail info@sick.pl

Republic of Korea

Phone +82-2 786 6321/4
E-Mail kang@sickkorea.net

Republika Slovenija

Phone +386 (0)1-47 69 990
E-Mail office@sick.si

România

Phone +40 356 171 120
E-Mail office@sick.ro

Russia

Phone +7 495 775 05 34
E-Mail info@sick-automation.ru

Schweiz

Phone +41 41 619 29 39
E-Mail contact@sick.ch

Singapore

Phone +65 6744 3732
E-Mail admin@sicksgp.com.sg

Suomi

Phone +358-9-25 15 800
E-Mail sick@sick.fi

Sverige

Phone +46 10 110 10 00
E-Mail info@sick.se

Taiwan

Phone +886 2 2375-6288
E-Mail sickgrc@ms6.hinet.net

Türkiye

Phone +90 216 587 74 00
E-Mail info@sick.com.tr

USA/Canada/México

Phone +1(952) 941-6780
1 800-325-7425 – tollfree
E-Mail info@sickusa.com

More representatives and agencies
in all major industrial nations at
www.sick.com

SICK | STEGMANN

SICK AG • Industrial Sensors • Waldkirch • Germany • www.sick.com
SICK STEGMANN GmbH • Donaueschingen • Germany • www.sick-stegmann.de