

**Single pole  
NO contactors  
C193 Series**

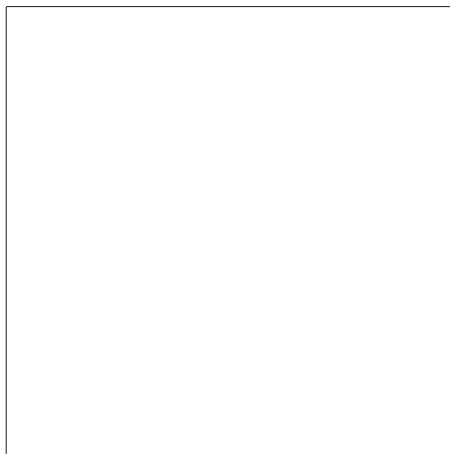
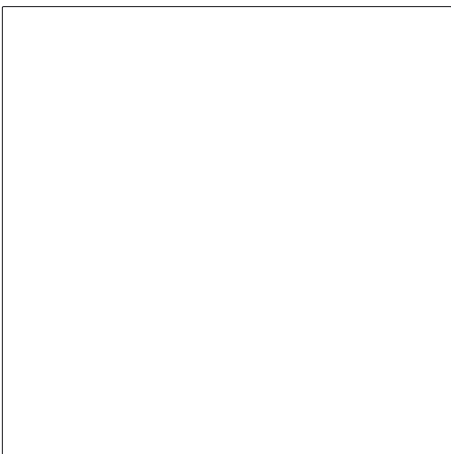
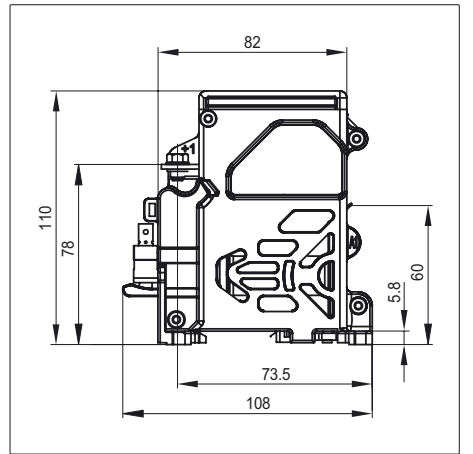
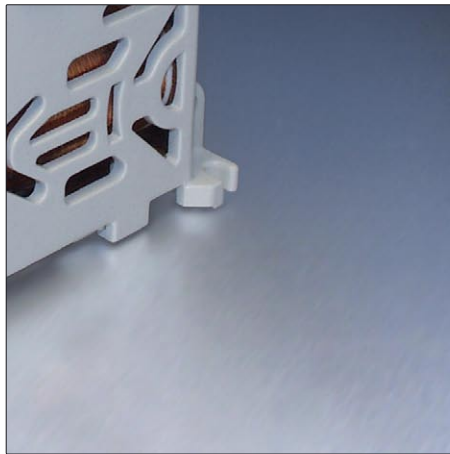
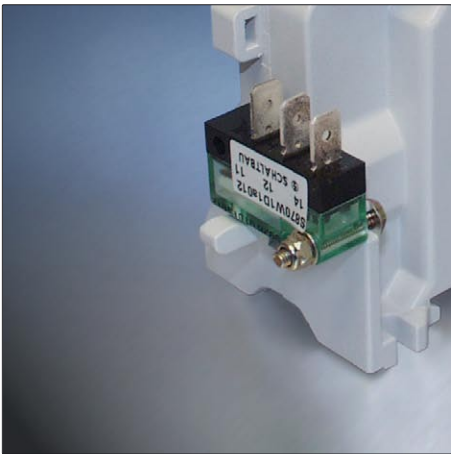
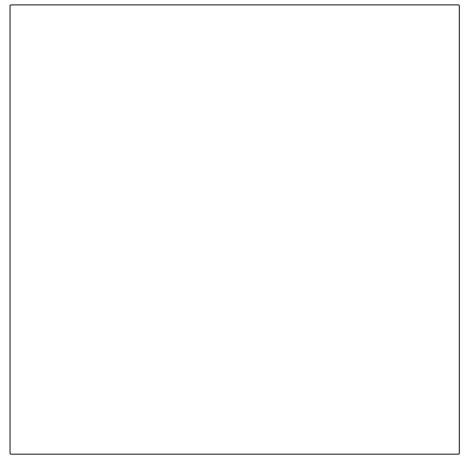

## Single pole NO contactor, C193 Series

**Single pole high-voltage contactor of compact design:** Notwithstanding its small size, the C193 Series contactor features an extraordinary switching capacity for DC applications up to 1,000 V.

Best suited for the harsh environment of public transport, the C193 has proven to be a transportation system component of high reliability which has an electrical life that is above average.

### Features

- Suitable for years of continuous duty
- Intended for high ambient temperatures
- Compact design
- Double-break contacts
- Versions for AC and DC operation
- DC versions with blowout magnets for arc quenching
- DIN rail mount option

### Applications

Typical applications are to be found in traffic engineering equipment, particularly in heating circuits, air conditioning equipment and conversion engineering of complex power supplies.

### Standards

Contactors meet requirements for industrial applications to:

**IEC 60947-1** Low-voltage switchgear and controlgear - Part 1: General rules.

**IEC 60947-4-1** Low-voltage switchgear and controlgear - Part 4-1: Contactors and motor starters - Electro-mechanical contactors and motor starters.

Meet requirements for railway applications to:

**IEC 60077-1**, Railway applications - Electric equipment for rolling stock - Part 1: General service conditions and general rules.

**IEC 60077-2**, Railway applications - Electric equipment for rolling stock - Part 2: Electrotechnical components; General rules.

### Ordering code

Example: **C193 A/ 24EV-U1**

#### Series

#### Version

- |   |   |
|---|---|
| A | for DC operation <b>with</b> baffles for arc quenching  |
| B | for AC operation <b>with</b> baffles for arc quenching* |
| S | for DC operation <b>without</b> baffles                 |
| T | for AC operation <b>without</b> baffles*                |

#### Coil voltages

24 / 36 / 72 / 110 V DC

#### Tolerance

E +25 % ... -30 %

#### Coil suppression

- |   |          |
|---|----------|
| V | Varistor |
| X | none     |

#### Auxiliary contacts

- |    |   |
|----|---|
| U1 | 1x snap-action switch S870 W1D4 a 012, pushbutton, silver plated contacts         |
| J1 | 1x snap-action switch S870 W1D4 a 063, gold plated contacts, terminals angled 45° |

\* AC version without magnetic blowout and without outward pole strip



Single pole NO contactor **C193 A/ 72EV-U1**

#### Note:

Presented in this catalogue are only stock items which can be supplied in short delivery time.

#### Special variant

If you need a special variant feel free to contact us. Maybe the type of contactor you are looking for is among our many **special designs**. If not, we also supply **customized designs**. In this case, however, minimum order quantities apply.

## Circuit and dimension diagram, Mounting

### Circuit diagram:

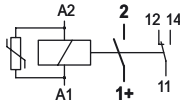

### Mounting:

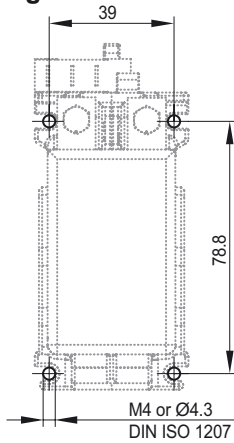

M4, tightening torque 2 Nm max.  
or DIN rail 35 mm

### Dimension diagram:

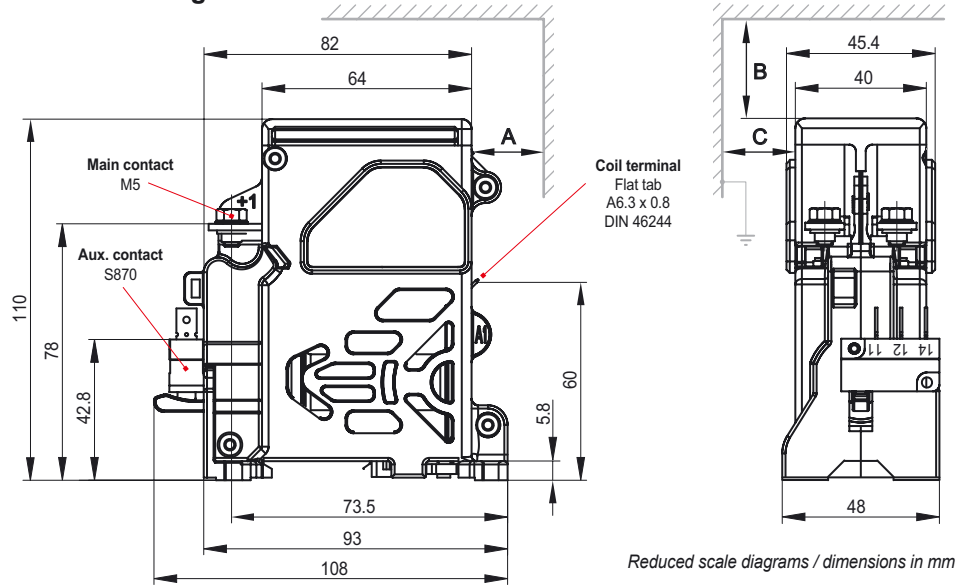

Reduced scale diagrams / dimensions in mm

**Note:**  
Clearance towards live or earthed parts  
≥ 10 mm!

Clearance towards plasma exit (see diagram):	A	B	C
P < rated power	10 mm	10 mm	10 mm
P ≥ rated power	10 mm	10 mm	50 mm

## Specifications

C193 Series, Version	A	B	S	T
Type of voltage	DC	AC	DC	AC
Main contacts, Number of, Configuration	1x SPST-NO	1x SPST-NO	1x SPST-NO	1x SPST-NO
Nominal voltage $U_n$	750 V	750 V	750 V	750 V
Rated insulation voltage $U_i$ to IEC 60947-1	1,000 V	1,000 V	1,000 V	1,000 V
Pollution degree	PD3	PD3	PD3	PD3
Overvoltage category	OV3	OV3	OV3	OV3
Conventional thermal current $I_{th}$ at $T_a = 70^\circ\text{C}$ , Wire cross-section 50 mm <sup>2</sup>	50 A	50 A	50 A	50 A
Making capacity (resistive, T = 0 ms)	600 A	600 A	600 A	600 A
Breaking capacity	1,000 V DC, L/R 1 ms: 90 A L/R 15 ms: 25 A	1,000 V AC, $\cos\phi$ 1.0: 140 A	220 V DC, L/R 1 ms: 1,200 A L/R 15 ms: 800 A	---
Switching off, no motor reversing circuits	only in one direction	---	only in one direction	---
Arc chute for DC / AC operation	•	---	---	---
Blowout, magnetic	•	---	•	---
Arc chamber for AC operation	---	•	---	---
Main contacts:				
Material	AgSnO <sub>2</sub>			
Terminals	M5, tightening torque 3 Nm max.			
Auxiliary contacts:				
Number of, configuration	1x snap-action switch S870, SPDT, optional (see also catalogue D70e)			
Utilization category (IEC 60947-5-1)	AC-15: 1.5 A at 230 V AC; DC-13: 0.5 A at 60 V DC or 2.0 A at 24 V DC			
Terminals	Quick-connect 6.3 x 0.8 mm			
Magnetic drive:				
Rated control supply voltage $U_s$	24 / 36 / 72 / 110 V DC			
Operating range of $U_s$	-30 % ... +25 % at $T_a = 70^\circ\text{C}$ max.			
Coil power dissipation ( $T_a = 20^\circ\text{C} / U_s$ )	Cold coil approx. 15 W, warm coil approx. 9 W			
Coil temperature	155° C at $T_{a,max}$ and $U_{s,max}$			
Coil suppression	Varistor			
Terminals	Quick-connect 6.3 x 0.8 mm			
Degree of protection (IEC 60529)	IP00			
Mechanical endurance	> 3 million operating cycles			
Electrical endurance	600,000 operating cycles ( $U_n = 1,000\text{ V DC}$ , $I_{th} = 30\text{ A}$ , L/R = 1 ms)			
Shock / Vibration (DIN EN 61373)	5g (20 ms half sinus) / 2g (5 ... 150 Hz)			
Duty cycle	100 %			
Mounting position	Any, except: do not mount upside down, so that mounting plate points upwards			
Temperature				
Operating temperature	-25° C ... +70° C			
Storage temperature	-40° C ... +80° C			
Weight	0.7 kg	0.7 kg	0.7 kg	0.7 kg



Schaltbau GmbH manufactures in compliance with RoHS.



Schaltbau GmbH has an environment management system that has been certified since 2002.



Schaltbau GmbH has a quality management system that has been certified since 1994.

## Electrical Components and Systems for Railway Engineering and Industrial Applications

### Connectors

- Connectors manufactured to industry standards
- Connectors to suit the special requirements of communications engineering (MIL connectors)
- Charging connectors for battery-powered machines and systems
- Connectors for railway engineering, including UIC connectors
- Special connectors to suit customer requirements

### Snap-action switches

- Snap-action switches with positive opening operation
- Snap-action switches with self-cleaning contacts
- Enabling switches
- Special switches to suit customer requirements

### Contactors

- Single and multi-pole DC contactors
- High-voltage AC/DC contactors
- Contactors for battery powered vehicles and power supplies
- Contactors for railway applications
- Terminal bolts and fuse holders
- DC emergency stop switches
- Special contactors to suit customer requirements

### Electrics for rolling stock

- Equipment for driver's cab
- Equipment for passenger use
- High-voltage switchgear
- High-voltage heaters
- High-voltage roof equipment
- Equipment for electric brakes
- Design and engineering of train electrics to customer requirements

## Schaltbau GmbH

Klausenburger Strasse 6  
81677 Munich  
Germany

Phone +49 89 9 30 05-0  
Fax +49 89 9 30 05-350  
e-Mail [contact@schaltbau.de](mailto:contact@schaltbau.de)  
Internet [www.schaltbau.com](http://www.schaltbau.com)

with compliments: